



**TECHNICAL INFORMATION**  
**CVA615 Coffee System**

**CVA615 Coffee System – Table of Contents**

<b>1.0</b>	<b>Construction and Design.....</b>	<b>9</b>
1.1	Appliance Overview .....	9
1.1.1	Front View.....	9
1.1.2	Controls .....	10
1.1.3	Interior (Front of Appliance Opened) .....	10
1.2	Technical Data.....	11
1.3	Layout of Components .....	12
<b>2.0</b>	<b>Installation .....</b>	<b>13</b>
<b>3.0</b>	<b>Commission and Operation .....</b>	<b>14</b>
3.1	General Operation .....	14
3.1.1	Preparing Coffee.....	14
3.1.2	Canceling the Preparation .....	15
3.1.3	Steam Control .....	15
3.1.4	Hot Water.....	16
3.1.5	Adjusting the Coffee Grinder .....	17
3.1.6	Filling the Coffee Beans Container .....	18
3.1.7	Filling the Water Tank.....	19
<b>4.0</b>	<b>Description of Function.....</b>	<b>20</b>
4.1	Door Switch .....	20
4.2	Overflow (Reed) Switch.....	20
4.3	Brew Unit – Cleaning and Care .....	21
4.4	Brew Unit Removal from the Appliance.....	21
4.5	Connection of Brew Unit to Drive Mechanism .....	22
4.6	Brewing Procedure .....	23
4.7	Grounds Container .....	26
4.8	Waste Unit Present Switch .....	26
4.9	Water Tank .....	28
4.10	Water Level Switch.....	29
4.11	Grinder Assembly .....	31
4.12	Grinder – Overload Protection.....	33
4.13	Ground Coffee Dispensing .....	35
4.14	Dispenser Switch.....	36
4.15	Brew Unit Drives.....	37
4.16	Water Pump.....	39
4.17	Flow Meter.....	39
4.18	Heaters .....	39
4.19	Flow Through Heaters .....	40
4.20	Water Path.....	42
4.20.1	Water Intake .....	43
4.20.2	Water Path - Coffee .....	43

**CVA615 Coffee System – Table of Contents (continued)**

4.20.3	Water Path – Hot Water .....	43
4.20.4	Water Path – Steam .....	43
4.21	Water Valve .....	44
4.22	Electronic Assemblies .....	45
4.22.1	Power Electronic .....	45
4.22.2	CPU Electronic .....	46
<b>5.0</b>	<b>Service and Maintenance .....</b>	<b>47</b>
5.1	Lid - Removal .....	47
5.2	Interference Suppression Filter (Z1) - Removal .....	48
5.3	Rear Panel - Removal .....	48
5.4	Adjustment Slide Switch Frame - Removal .....	49
5.5	Door Contact Switch (S24) - Removal.....	50
5.6	Base Plate - Removal.....	51
5.7	Drip Tray - Removal .....	52
5.8	Overflow Switch Actuator Float - Removal .....	53
5.9	Overflow Switch (B8/3) - Removal.....	54
5.10	Rear Door Panel - Removal .....	55
5.11	Fascia Panel Cover - Removal.....	56
5.12	Selector Switch - Removal .....	57
5.13	Display Module Electronic - Removal.....	58
5.14	Coffee Dispensing Nozzle - Removal.....	59
5.15	Coffee Dispensing Nozzle - Installation.....	60
5.16	Steam Valve and Steam Valve Switch (S79) - Removal .....	61
5.17	Hot Water Nozzle - Removal .....	62
5.18	Hot Water Valve (Y12) - Removal .....	62
5.19	Checking Temperature at Coffee Dispenser .....	63
5.20	Brew Unit – Removal (in Start/Home Position).....	64
5.21	Brew Unit – Removal (NOT in Start/Home Position) .....	65
5.22	Brew Unit - Installation.....	67
5.23	Brew Unit – Cleaning Procedure .....	67
5.24	Brew Unit – Filter Cleaning.....	68
5.25	Brew Unit – Degreasing via the Rinse Cycle .....	69
5.26	Brew Unit - Lubrication .....	71
5.27	Brew Unit – Manual Reset to “Home Position” (with Brew Unit Not Installed in Appliance) .....	72
5.28	Brew Unit Creamer Valve - Removal.....	73
5.29	Brew Unit Handle - Removal .....	73
5.30	Brew Unit Funnel - Removal.....	74
5.31	Brew Unit Ram - Service .....	75
5.32	Brew Unit Drives - Service.....	77
5.33	Water Tank Float - Removal.....	82
5.34	Water Tank Lip Seal - Removal.....	83
5.35	Lower Section of Tank Valve - Removal .....	84
5.36	Beans Container - Removal .....	86

## Technical Information

**CVA615 Coffee System – Table of Contents (continued)**

5.37	Beans Container Guide - Removal.....	87
5.38	Grinder - Disassembly.....	88
5.39	Grinder Assembly – Basic Setting.....	91
5.40	Grinder Unit - Removal.....	92
5.41	Dispensing Solenoid - Removal.....	93
5.42	Dispenser Switch - Removal.....	93
5.43	Waterpath & Flowmeter - Testing.....	94
5.44	Water Path Leakage Test.....	96
5.45	Water Path Connections - Opening.....	97
5.46	Water Path Connections - Closing.....	97
<b>6.0</b>	<b>Fault Diagnosis.....</b>	<b>98</b>
6.1	Programming Mode.....	98
6.2	Service Mode.....	99
6.3	Displayed Messages.....	101
6.4	Fault Diagnosis.....	103

**CVA615 Coffee System – List of Figures**

Figure 1-1: Front Overview CVA615.....	9
Figure 1-2: CVA Controls.....	10
Figure 1-3: Interior View of CVA615 with Door Opened .....	10
Figure 1-4: CVA615 Product Dimensions .....	11
Figure 1-5: CVA615 Overhead View of Components .....	12
Figure 2-1: Operating Manual.....	13
Figure 3-1: Cup Under the Dispensing Ports.....	14
Figure 3-2: Pressing the Coffee Button.....	14
Figure 3-3: Displayed Message .....	14
Figure 3-4: Canceling the Preparation Process.....	15
Figure 3-5: Steam Selector .....	15
Figure 3-6: Placement of Cup Under the Hot Water Dispenser.....	16
Figure 3-7: Hot Water Button .....	16
Figure 3-8: Grinder Controls .....	17
Figure 3-9: Adding Coffee Beans.....	18
Figure 4-1: Door Contact Switch (S24).....	20
Figure 4-2: Brew Unit in “Home” Position .....	21
Figure 4-3: Brew Unit Connections .....	22
Figure 4-4: Brew Unit Filters .....	23
Figure 4-5: Brew Unit Components.....	24
Figure 4-6: Brew Unit, Showing Compressed Coffee “Puck” .....	25
Figure 4-7: Waste Unit Present Switch .....	26
Figure 4-8: Waste Unit.....	27
Figure 4-9: Water Tank.....	28
Figure 4-10: Water Level Switch.....	29
Figure 4-11: Water Level Switch Float.....	29
Figure 4-12: Grinder Assembly .....	31
Figure 4-13: Components of the Grinder Overload Protection .....	33
Figure 4-14: Ball Positions into the Grinder Cone, Under Different Operating Conditions.....	34
Figure 4-15: Coffee Dispensing Components.....	35
Figure 4-16: Dispensing Lever.....	36
Figure 4-17: Components of the Brew Unit Drive Assembly, Water Connection and Present Switch.....	37
Figure 4-18: Brew Unit Drive Assembly .....	38
Figure 4-19: Hot Water / Coffee Heater .....	40
Figure 4-20: Steam Heater .....	41
Figure 4-21: Water Path.....	42
Figure 4-22: Water Valve (Disassembled).....	44
Figure 4-23: Power Electronic Board .....	45
Figure 4-24: CPU (Control) Electronic .....	46

**CVA615 Coffee System – List of Figures (continued)**

Figure 5-1: Lid with Screws.....	47
Figure 5-2: Interference Suppression Filter (Z1) Mounting Location .....	48
Figure 5-3: Rear Panel Removal .....	48
Figure 5-4: Removing the Adjustment Slide Switch Frame (Bezel) .....	49
Figure 5-5: Door Switch (Shown with Appliance Door in Open Position) .....	50
Figure 5-6: Base Plate - Removal.....	51
Figure 5-7: Drip Tray Removal.....	52
Figure 5-8: Overflow Switch Actuator Float .....	53
Figure 5-9: Overflow Switch.....	54
Figure 5-10: Rear Door Panel - Removal .....	55
Figure 5-11: Fascia Panel Cover Assembly.....	56
Figure 5-12: Selector Switch.....	57
Figure 5-13: Rear View of Front Door with Rear Panel Removed .....	58
Figure 5-14: Components of the Coffee Dispensing Nozzle.....	59
Figure 5-15: Components of Steam Valve and Steam Valve Switch.....	61
Figure 5-16: Hot Water Valve Components .....	62
Figure 5-17: Brew Unit.....	66
Figure 5-18: Brew Unit Connection Socket Retaining Screw and Locking Tab .....	66
Figure 5-19: Brew Unit – Removal for Cleaning .....	67
Figure 5-20: Brew Unit Installation.....	68
Figure 5-21: Cleaning Tablet being Placed into the Brew Unit Funnel .....	69
Figure 5-22: Brew Unit Lubrication Points .....	71
Figure 5-23: Brew Unit Lubrication Points .....	71
Figure 5-24: Moving the Brew Unit to “Home Position”.....	72
Figure 5-25: Brew Unit in Reset Position .....	72
Figure 5-26: Brew Unit – Highlighting the Output Assembly (Covering the Cream Valve) and Retaining Lugs for Securing the Handle to the Brew Unit Body .....	73
Figure 5-27: Rear of the Brew Unit, Highlighting the Funnel Lock.....	74
Figure 5-28: Front of Brew Unit, Showing Spring Location and Holder .....	74
Figure 5-29: Releasing the Ram from the Bottom of the Brew Unit.....	75
Figure 5-30: Brewing Unit Chamber Inside the Brew Unit Assembly.....	76
Figure 5-31: Ram Assembly .....	76
Figure 5-32: Front Plate Assembly with Retaining Screw Locations .....	78
Figure 5-33: Grinder Retaining Screws.....	79
Figure 5-34: Grinder Retaining Nuts .....	79
Figure 5-35: Upper Front Plate Assembly Retaining Screws.....	80
Figure 5-36: Using a Suitable Item to Keep the Front Plate Assembly Elevated to Access the Screws at the Bottom .....	81
Figure 5-37: Removing the Cap to Access the Float in the Water Container .....	82
Figure 5-38: Levering Off the Lip Seal Cap .....	83
Figure 5-39: Removing the Lip Seal .....	83
Figure 5-40: Water Tank Lip Seal Removal.....	84
Figure 5-41: Underside View of the CVA615 with Base Plate and Drip Tray Removed .	85
Figure 5-42: Removing the Beans Container.....	86

**CVA615 Coffee System – List of Figures (continued)**

Figure 5-43: Beans Container Guide .....	87
Figure 5-44: Grinder - Disassembly .....	88
Figure 5-45: Grinder.....	89
Figure 5-46: Grinder - Apart.....	90
Figure 5-47: Grinder Removal .....	92
Figure 5-48: Grinder Coupling .....	93
Figure 5-49: Test Jumper Position.....	95
Figure 5-50: Display While in Service Mode .....	95
Figure 5-51: Water Path Connection .....	97

---

**Technical Information****CVA615 Coffee System – List of Tables**

Table 6-1:	Programming Mode Navigation .....	98
Table 6-2:	Service Mode Navigation.....	100
Table 6-3:	Displayed Messages (Continued on Table 6-4) .....	101
Table 6-4:	Displayed Messages (Continued from Table 6-3) .....	102



## 1.0 Construction and Design

### 1.1 Appliance Overview

#### 1.1.1 Front View

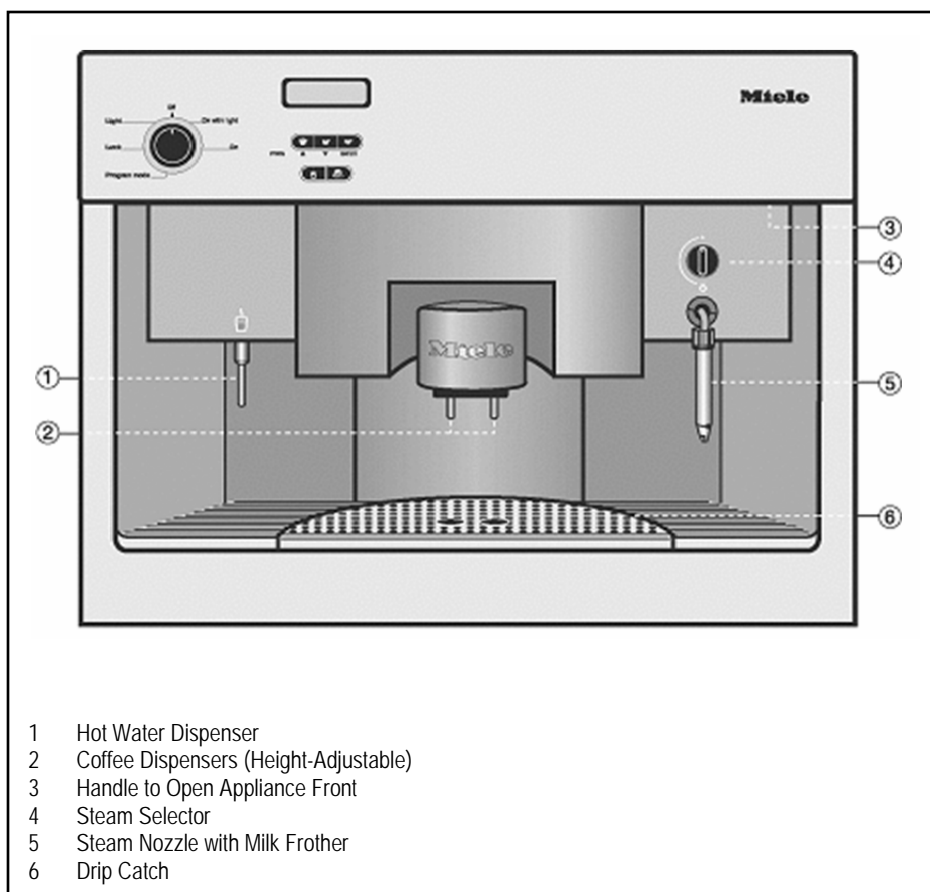

**Figure 1-1:** Front Overview CVA615

## Technical Information

## 1.1.2 Controls

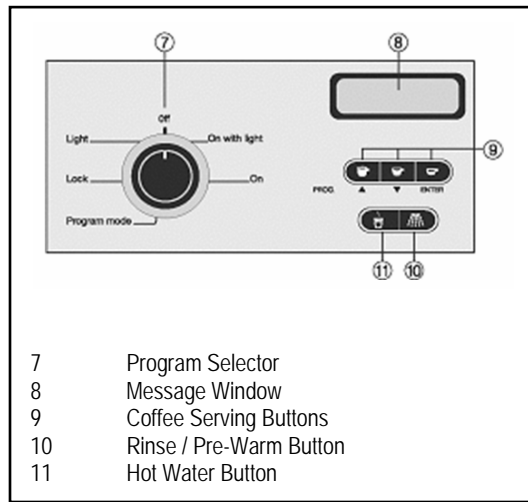

Figure 1-2: CVA Controls

## 1.1.3 Interior (Front of Appliance Opened)

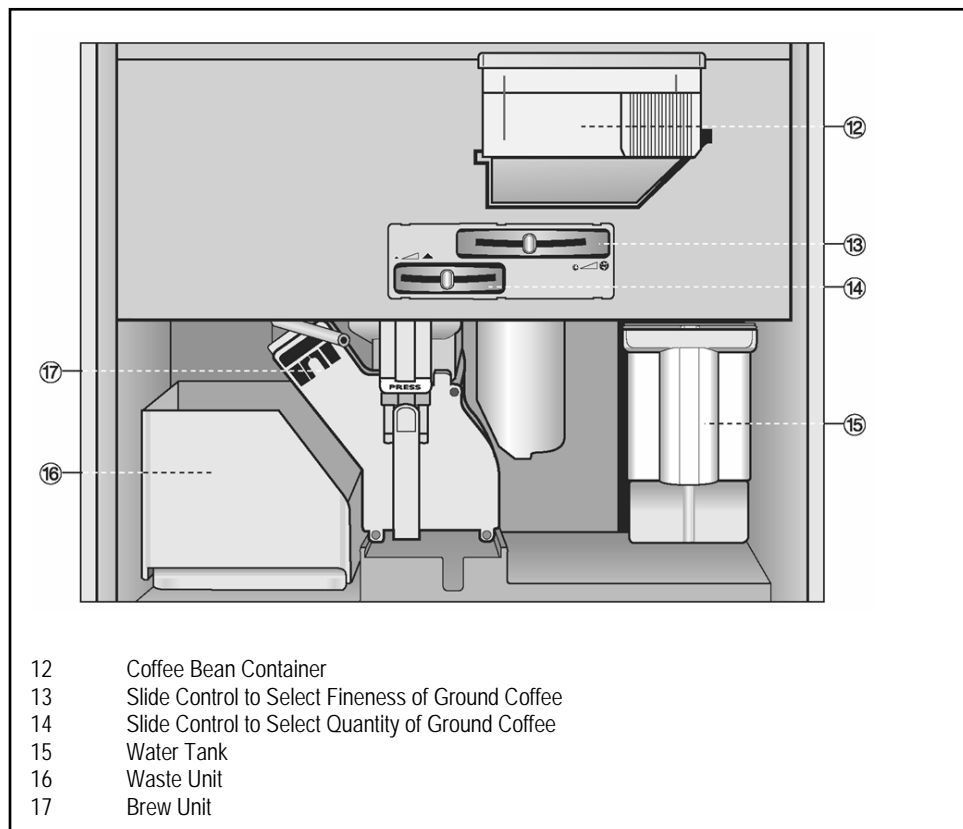

Figure 1-3: Interior View of CVA615 with Door Opened

## 1.2 Technical Data

### Product Dimensions

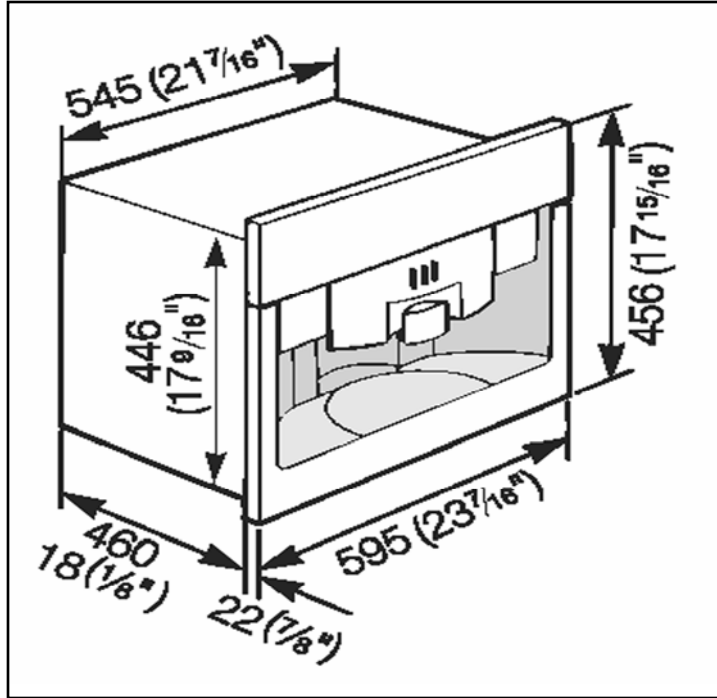
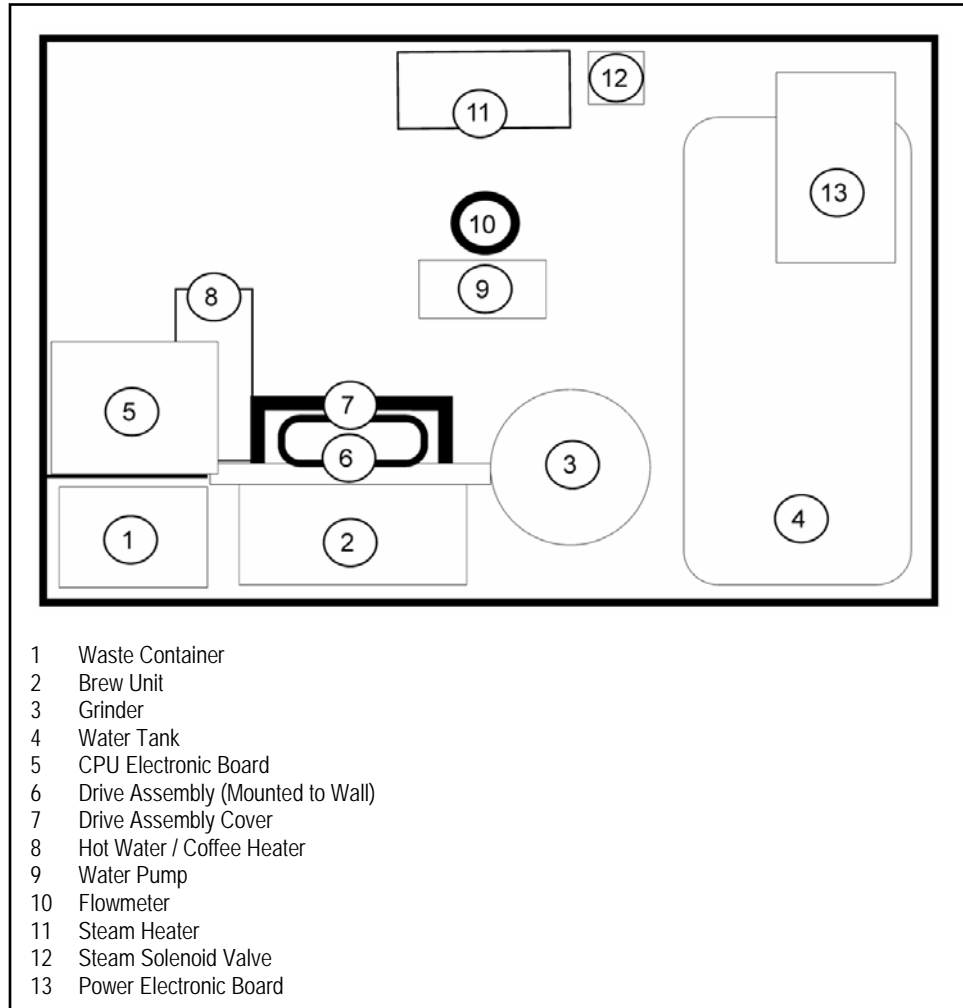

Figure 1-4: CVA615 Product Dimensions

### Electrical Information

The appliance comes equipped with a 6ft (1.8 m) power cord with a NEMA 5-15P molded plug for connection to a 120 V, 15 A, 60 Hz power supply.

## Technical Information

**1.3 Layout of Components****Overhead View of Main Components****Figure 1-5: CVA615 Overhead View of Components**

## 2.0 Installation

Refer to the Installation section of the Operating Manual.

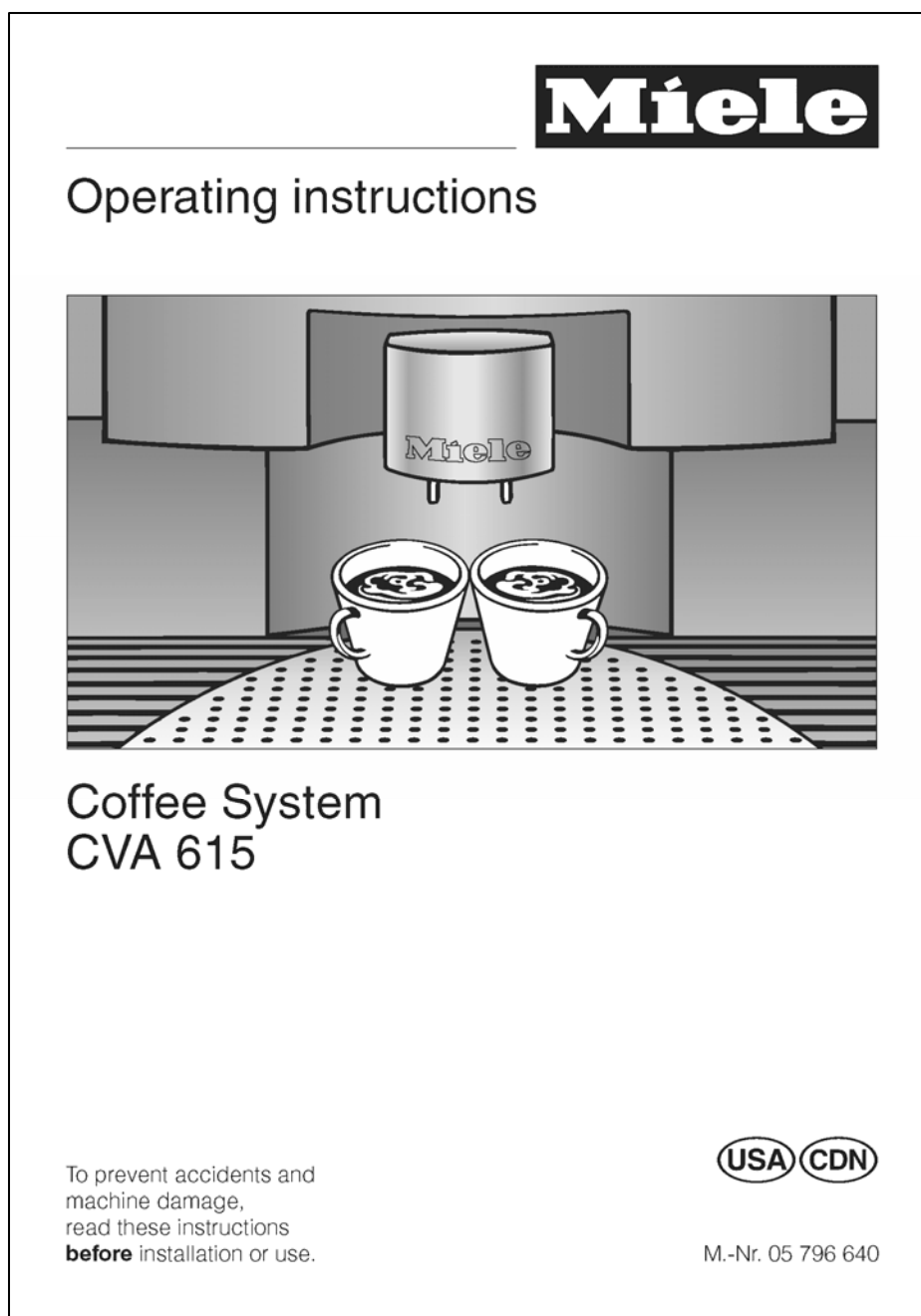

Figure 2-1: Operating Manual

## Technical Information

## 3.0 Commission and Operation

### 3.1 General Operation

#### 3.1.1 Preparing Coffee

1. Place a cup under both coffee dispensing ports.



Figure 3-1: Cup Under the Dispensing Ports

2. Press the desired size coffee button once. This will start the preparation cycle.



Figure 3-2: Pressing the Coffee Button

The following message will appear in the message window, depending on the button pressed:



Figure 3-3: Displayed Message

### 3.1.2 Canceling the Preparation

Press any one of the coffee buttons to stop preparation immediately.



**Figure 3-4:** Canceling the Preparation Process

### 3.1.3 Steam Control

**Caution:**

The steam from the appliance is extremely hot; use caution to prevent burns.

- Turn the steam ON by turning the Steam Selector counter-clockwise.
- Turn the steam OFF by turning the Steam Selector clockwise.

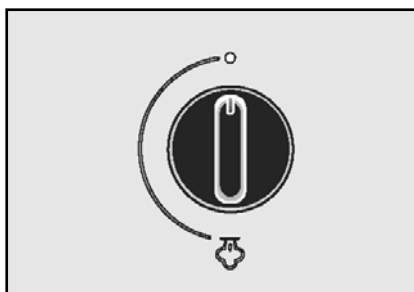
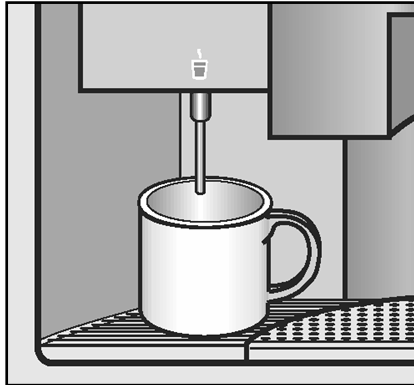

**Figure 3-5:** Steam Selector

## Technical Information

**3.1.4 Hot Water**

1. Place a cup under the hot water dispenser.



**Figure 3-6:** Placement of Cup Under the Hot Water Dispenser

2. Press the hot water button. Hot water will be dispensed.
3. Press the hot water button again to stop the flow of hot water.



**Figure 3-7:** Hot Water Button

**Note:**

If programmed with the hot water feature activated...  
The flow of hot water will stop automatically once a predetermined amount of hot water has passed through the system



### 3.1.5 Adjusting the Coffee Grinder

#### Controls

- Slide to the left for finer grinding.
- Slide to the right for coarser grinding.

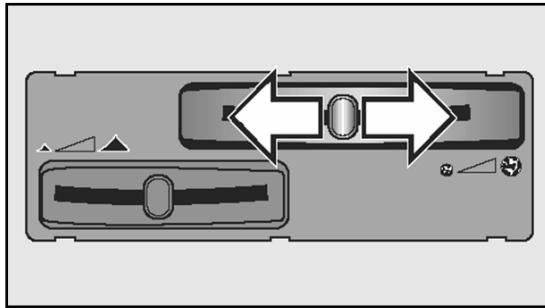

**Figure 3-8:** Grinder Controls

- If the espresso flows too quickly into the cup, the beans may have been ground too coarsely. The grinder should be adjusted to a finer setting.
- If the espresso only trickles into the cup, the beans may have been ground too fine and the coffee will be bitter. The grinder should be adjusted to a coarser setting.
- If the crema is evenly colored but pale, the ground coffee is too coarse.
- If the crema is very dark brown on one side, graduating almost to white on the other, the ground coffee is too fine.

#### Note:

- You should be able to feel notches when moving the slide control.
- If the slide control will not move:  
Close the machine and dispense a cup of coffee. Then try to move the slide control again.

## Technical Information

**3.1.6 Filling the Coffee Beans Container**

1. Open the appliance door.
2. Carefully slide the container out so that the lid is visible.
3. Lift the lid.
4. Fill the container with coffee beans to about 1" from the top.
5. Close the lid and push the container back into place.
6. Shut the appliance door.

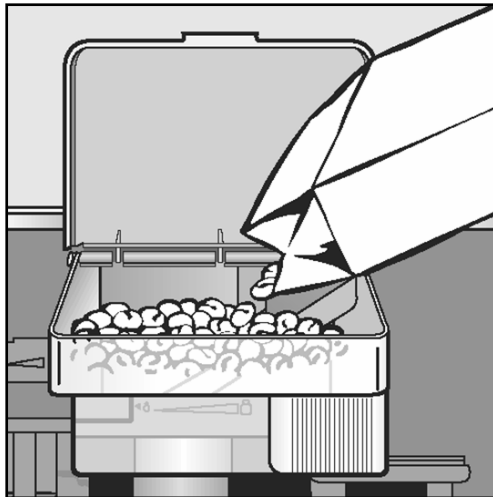
**Figure 3-9:** Adding Coffee Beans**Important!**

Only put whole espresso or coffee beans in the container. Anything else, including ground coffee, hot cocoa, instant coffee, or treated coffee beans (flavorings, caramel, or sugar) will damage the grinder.

**Note:**

Do not remove the coffee bean container from the appliance unless it is completely empty, otherwise coffee beans will spill out.

### 3.1.7 Filling the Water Tank

The water tank must be washed and filled with fresh drinking water each day. A reminder will appear in the message window when the unit is first turned on.

1. Open the front of the machine.
2. Lift the water tank up and out of the appliance.
3. Open the lid and fill the container with cold drinking water to within about 1" (2 cm) of the top.

**Important!**

Never add hot water or any other liquid except cold water to the water tank.

4. Close the lid and place the tank in the machine, pushing it straight back.
5. Close the front of the appliance.

## Technical Information

## 4.0 Description of Function

### 4.1 Door Switch

The door switch, removes power to the appliance when the door is opened. Refer to Figure 4-1 – Door Contact Switch (S24).

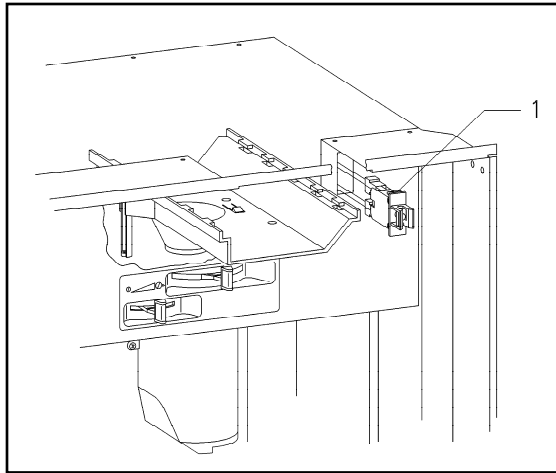

Figure 4-1: Door Contact Switch (S24)

### 4.2 Overflow (Reed) Switch

The overflow switch is in the lower section of the appliance case. The float with magnet is located in the drip tray. Should a leak develop, water flows into the drip tray. The float with magnet then rises and activates the overflow reed switch which in turn causes the electronic control to switch the unit off.

**Note:**

When the Service Mode is accessed, the top line of the display shows the switches that are activated. An "A" will be displayed if the Overflow Switch is actuated. (i.e. water present in the bottom of the appliance) Refer to Section 6 for more information on the Service Mode.

### 4.3 Brew Unit – Cleaning and Care

The Brew Unit is a mechanically operated component that is subjected to high forces. After a long period of use, the Brew Unit may become clogged. To ensure correct operation of the Brew Unit, it is essential to clean it regularly and apply silicone grease to the moving parts. Refer to Section 5.0 – Service and Maintenance for further information and procedures.

### 4.4 Brew Unit Removal from the Appliance

The brew unit must be in the home position (refer to Figure 4-2) before it can be removed from the appliance.

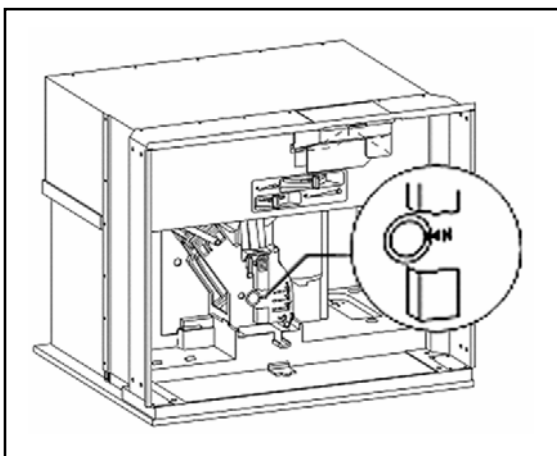

**Figure 4-2:** Brew Unit in “Home” Position

## Technical Information

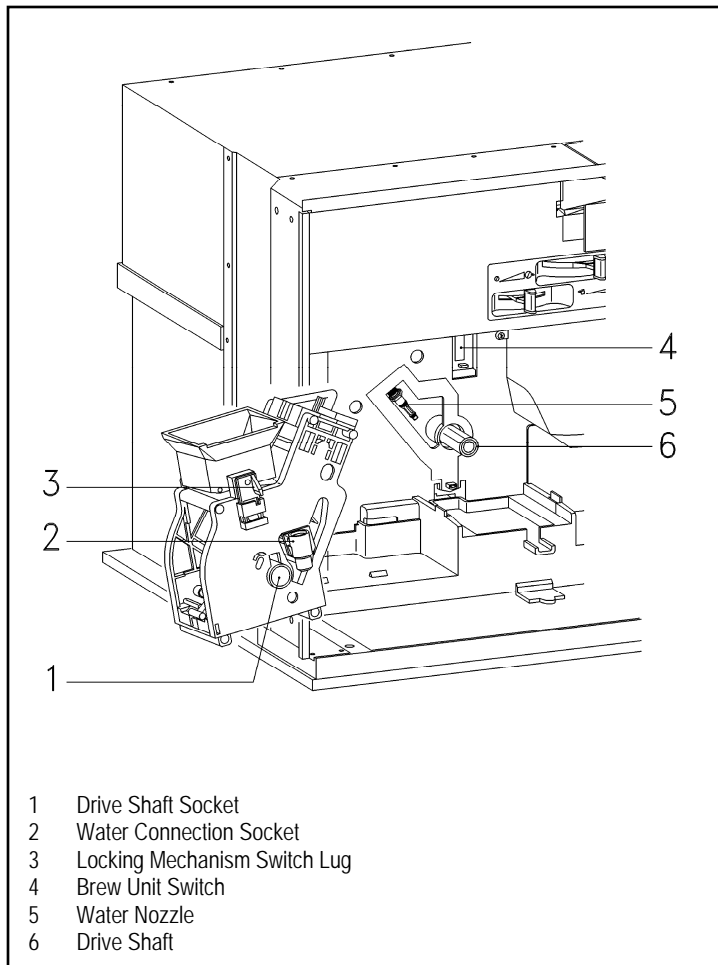
**4.5 Connection of Brew Unit to Drive Mechanism****Figure 4-3:** Brew Unit Connections**Operation**

Refer to Figure 4-3 – Brew Unit Connections.

When the Brew Unit is placed into in the appliance, it locks into position. The locking mechanism Switch Lug (Item 3), activates the Brew Unit Switch (Item 4). The Drive Shaft (Item 6) engages with the Brew Unit Drive Shaft Socket (Item 1). The Nozzle (Item 5), supplies the Brew Unit with hot water under pressure. When the Brew Unit is in the brewing position, the socket (Item 2), allows hot water to pass through the coffee.

## 4.6 Brewing Procedure

1. The grinder fills the dispenser housing until full (as determined by the dispenser switch).
2. The grinder is then switched off.
3. The dispenser flap opens twice (two clicks) via the dispenser solenoid assembly.
4. The ground coffee then falls into the brew unit via the funnel.

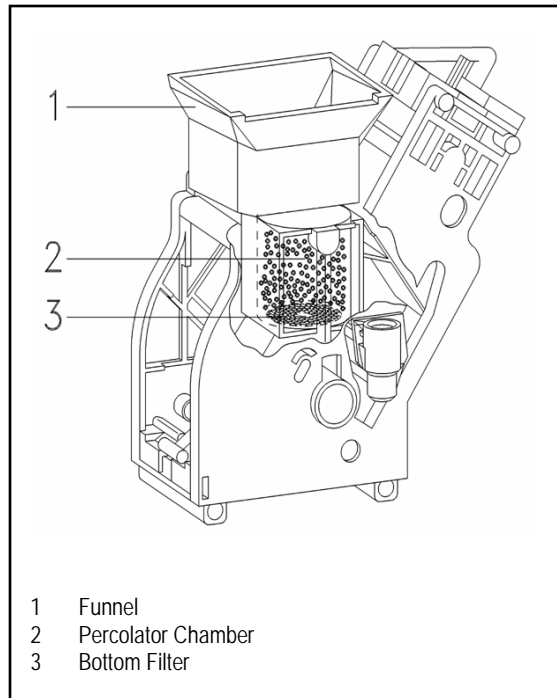
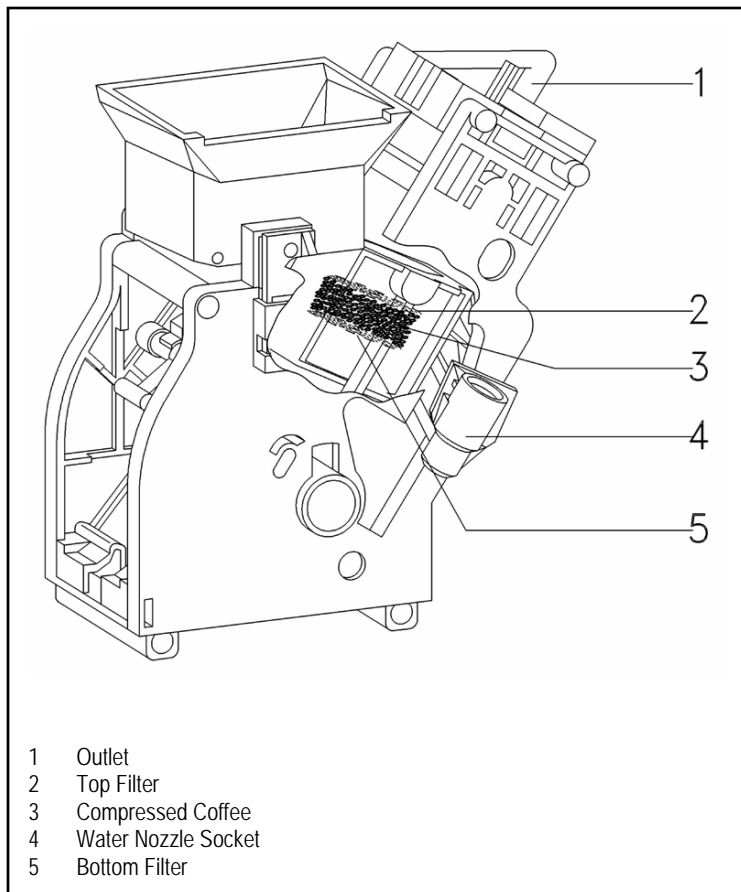

**Figure 4-4:** Brew Unit Filters

Refer to Figure 4-5 – Brew Unit Components.

5. The drive tilts the percolator chamber and raises it to the brewing position. The ground coffee is compressed between the Top Filter (Item 2) and Bottom Filter (Item 5).
6. Water then flows through the Water Nozzle Socket, (Item 4). The pump forces the hot water through the Brew Unit and the compressed grounds (Pos 3). Coffee exits the top of Brew Unit via the Outlet (Item 1).

## Technical Information

**Figure 4-5: Brew Unit Components**



Refer to Figure 4-6 – Brew Unit, Showing Compressed Coffee “Puck”.

7. As the drive begin to move back toward the starting (home) position the coffee chamber moves upward and releases the used compressed coffee grounds (puck). Pos. 1.
8. The drive continues and returns the brew unit to its starting (home) position.

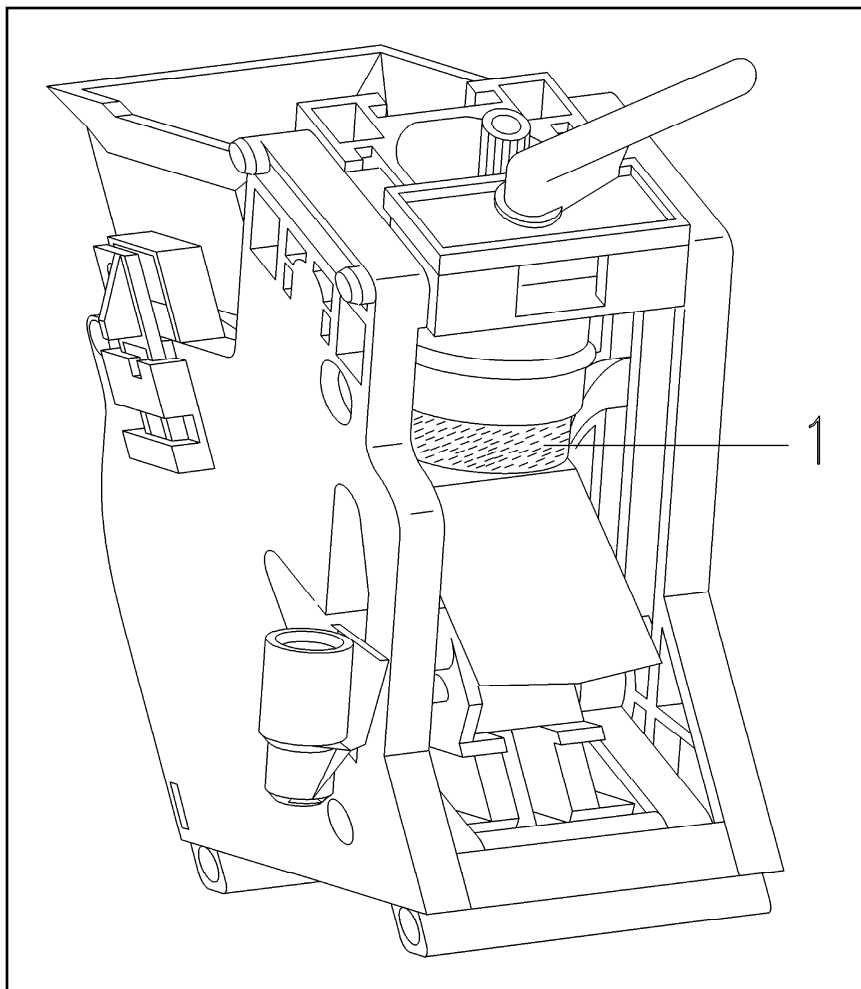

**Figure 4-6:** Brew Unit, Showing Compressed Coffee “Puck”

## Technical Information

**4.7 Grounds Container**

After coffee has been prepared, the coffee grounds compressed puck falls into the waste container. The electronic monitors the number of the compressed pucks. After a specific amount is reached, the message "Empty waste unit" is displayed.

**4.8 Waste Unit Present Switch**

A reed switch is mounted to the bottom of the housing – as shown in the Figure 4-7.

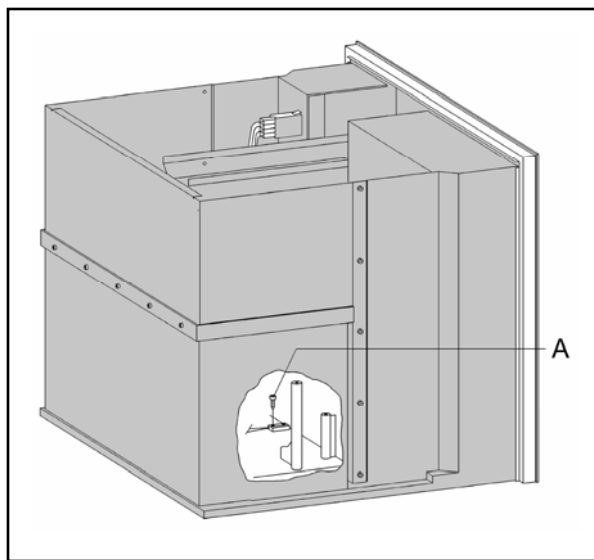

**Figure 4-7:** Waste Unit Present Switch

## Technical Information

The actuating magnet (Figure 4-8, Item 1) for the Waste Unit switch is fitted in the bottom edge of the container. The electronic monitors whether the waste unit is installed.

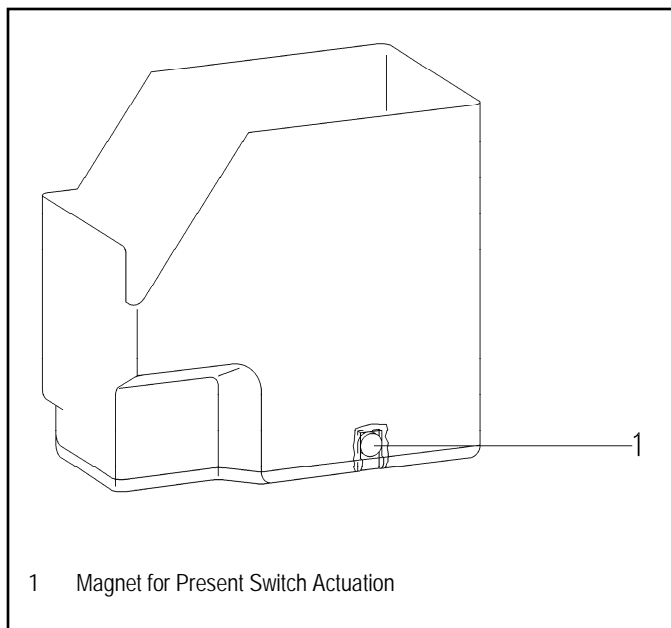

**Figure 4-8:** Waste Unit

When the appliance is placed into the Service Mode, the top line of the display shows the switches that have been activated. A “5” is displayed when the Waste Unit is installed and the switch is actuated. For further information, refer to Section 6 – Service Mode.

**Note:**

On newer Waste Units, an additional magnet has been installed that assists in keeping the waste unit attached to the metal frame inside the appliance.

## Technical Information

**4.9 Water Tank**

Refer to Figure 4-9 – Water Tank.

The Water Tank holds the water required for the brewing of the coffee, hot water and steam. When the Water Tank is installed, the sealing ring is pressed upwards allowing water to flow out.

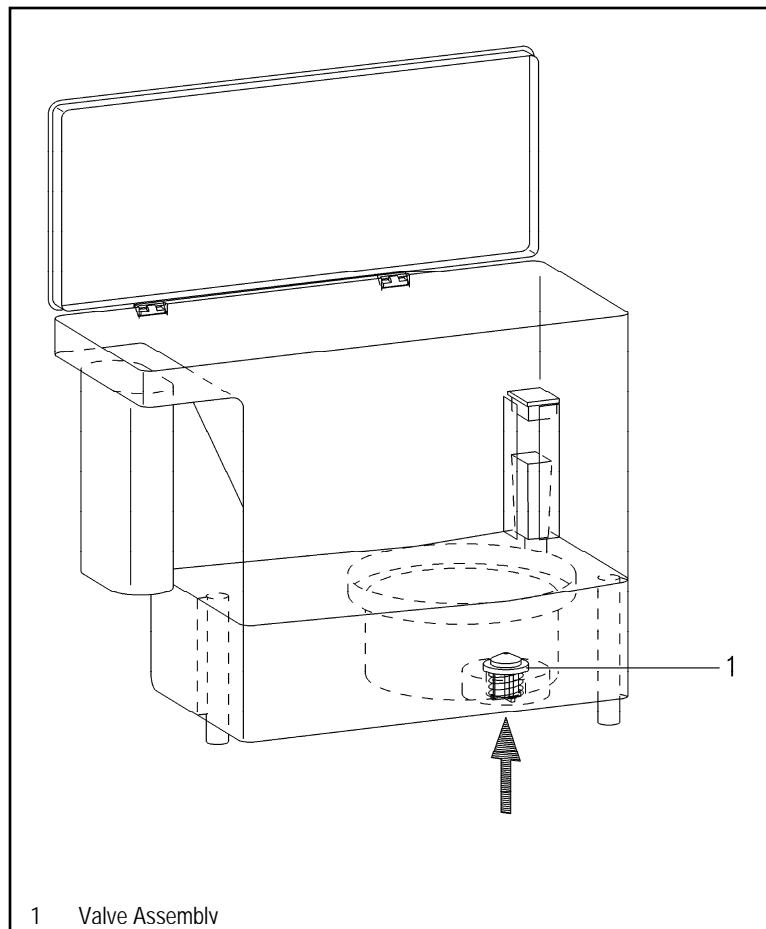
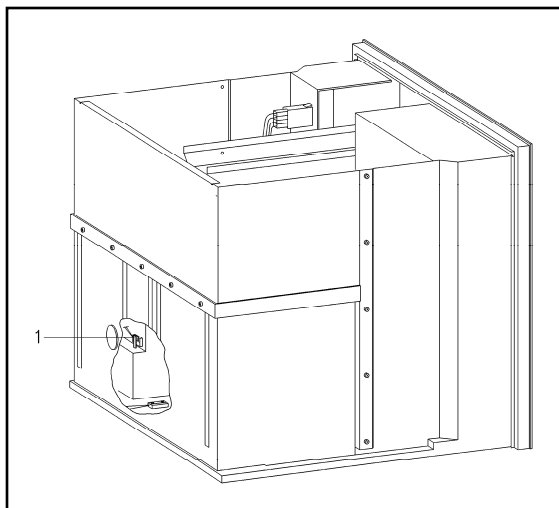

**Figure 4-9:** Water Tank

When the tank is removed from the unit, the spring closes the sealing ring to ensure water cannot flow from the tank when it is out of the appliance for filling etc...

## 4.10 Water Level Switch

The Water Level Switch is located within the housing (as shown in Figure 4-10, Item 1).



**Figure 4-10:** Water Level Switch

The actuating magnet for the Water Level Switch is located in the Water Tank as shown below (Figure 4-11, Item 1).

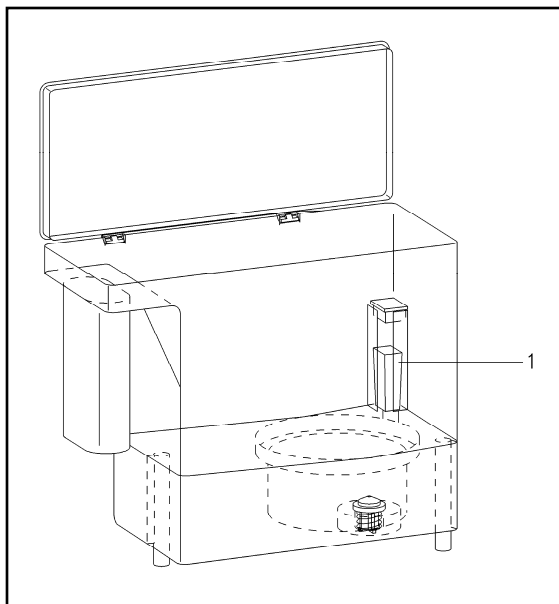

**Figure 4-11:** Water Level Switch Float

**Technical Information**

When the water tank is installed, and contains at least 30-33 ounces of water; the Water Level Switch is activated and its contacts close.

If the water quantity drops below the minimum quantity, the water level switch is no longer activated and the contacts open.

After the switch opens, the water passing through the water pump is registered via the flowmeter and recorded by the electronic unit as up to 27 ounces of water is still available.

After the 27 ounces is calculated as being used, the display shows "Fill water tank". To prevent the water pump from running dry, about 3 – 7 ounces of water remains in the tank.

If the appliance is placed into the service mode the top line of the display shows the switches that have been activated. A "7" is displayed when the water tank is installed and filled with water. Refer to section 6 – Service Mode for further information.

### 4.11 Grinder Assembly

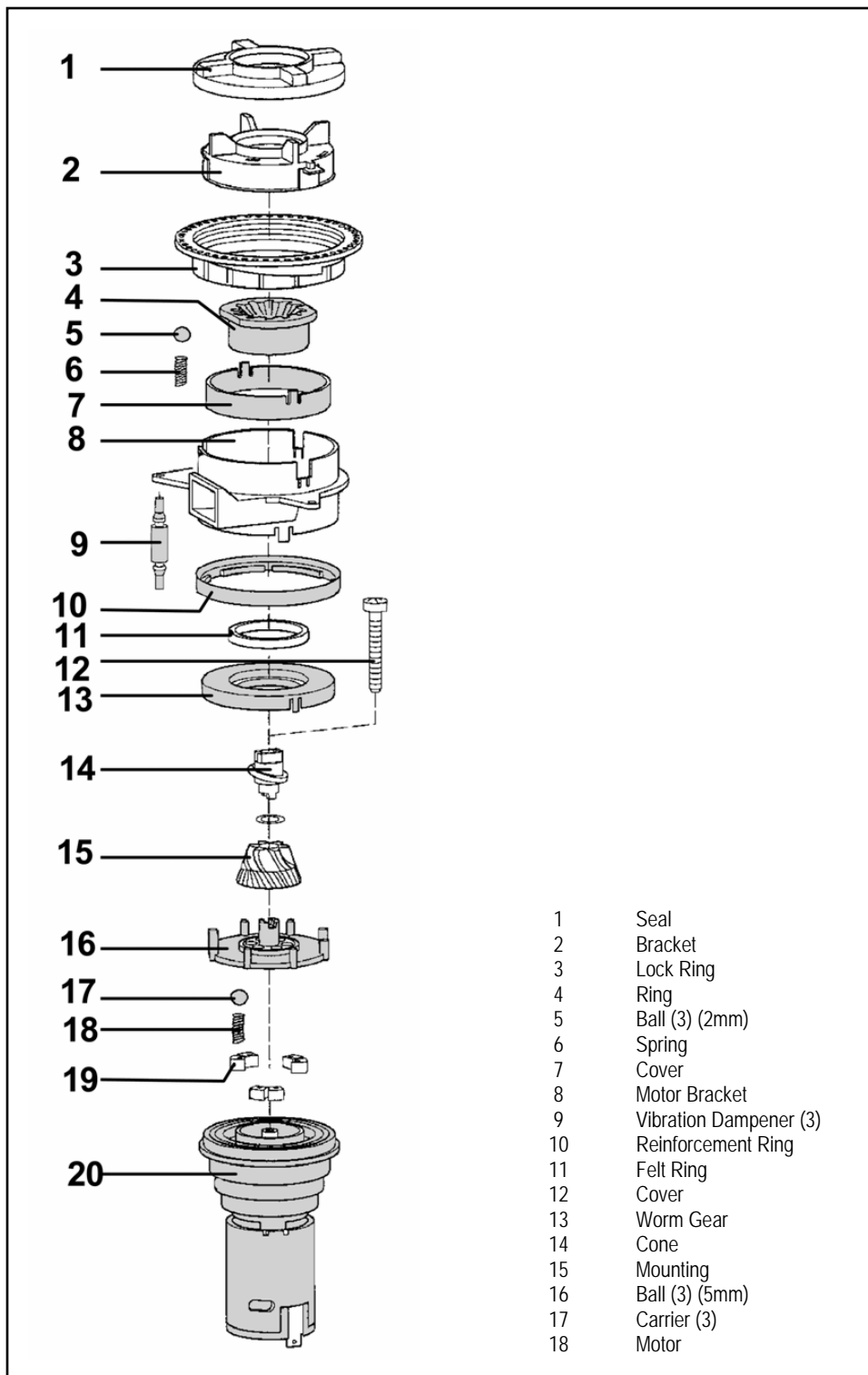

Figure 4-12: Grinder Assembly

**Technical Information**

Refer to Figure 4-12 – Grinder Assembly.

The grinding grade depends on the gap between the Grinding Cone and the Grinding Ring.

The gap is set via an adjustment lever fitted to the adjustment ring.

The smaller the gap, the finer the coffee grind.

**Warning!**

To avoid damage to the grinder, the grinder should only be adjusted in small steps.



## 4.12 Grinder – Overload Protection

If the grinder becomes blocked, a slip coupling interrupts the drive between the motor and the grinder.

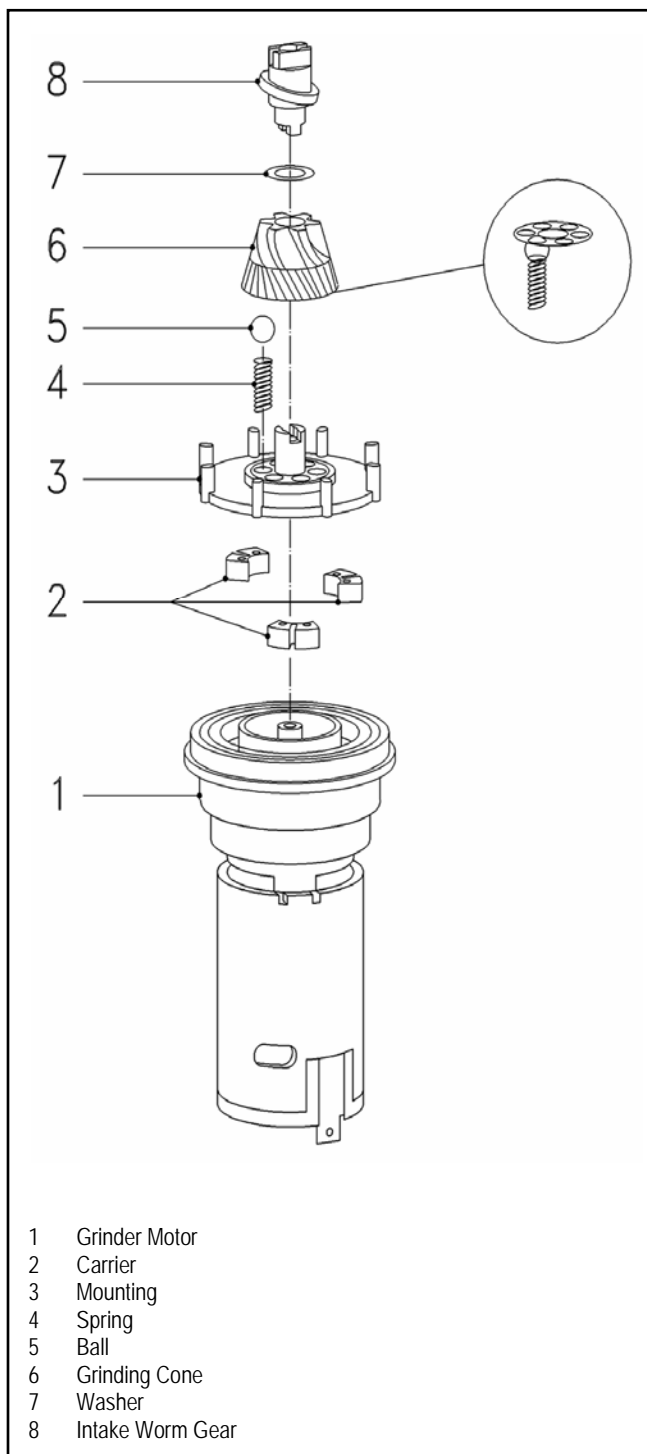

**Figure 4-13:** Components of the Grinder Overload Protection

**Technical Information**

Refer to Figure 4-13 – Components of the Grinder Overload Protection.

The Grinder Motor (Item 1) drives the mounting (Item 3) via the carriers (Item 2). The rotary force is then transferred via the balls, (Item 5) to the grinder cone (Item 6).

Should the Grinder Cone become blocked the balls are pressed into the mounting (as shown below in figure C). The drive force is interrupted; and the worm gear continues to operate via the mounting.

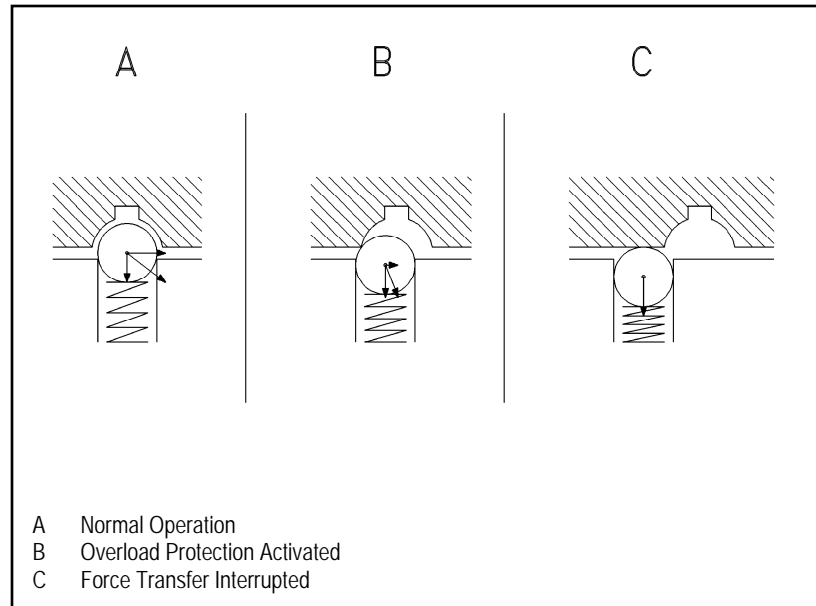

**Figure 4-14:** Ball Positions into the Grinder Cone, Under Different Operating Conditions

## 4.13 Ground Coffee Dispensing

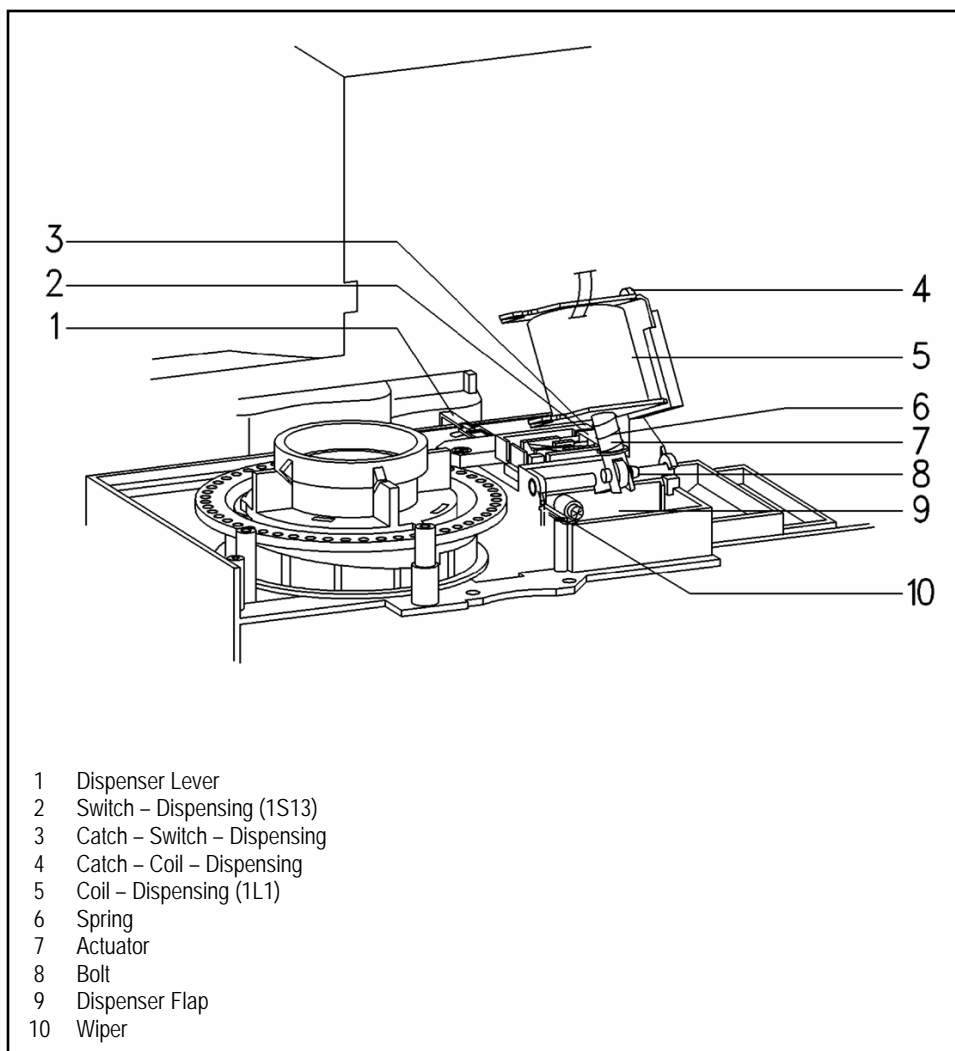
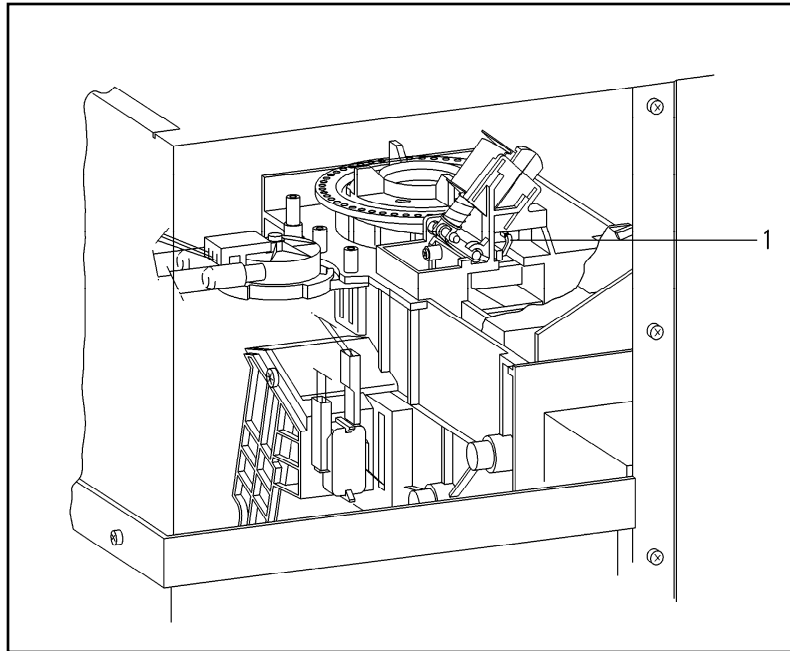

**Figure 4-15:** Coffee Dispensing Components

By adjusting the dispenser lever (Figure 4-15, Item 1), the position of the switch slide, in the dispenser container is modified. This changes the volume of the dispenser container and hence the quantity of ground coffee that it can hold before it is full. Each slider setting alters the coffee quantity by approx. 0.5 grams.

**Technical Information**

The grinder fills the dispenser container with ground coffee. When the dispenser container is full, the dispensing switch is actuated and the grinder motor is switched off.



**Figure 4-16:** Dispensing Lever

To fill the brew unit - the dispensing solenoid is energized twice and the dispenser flap opens twice. The ground coffee drops from the dispenser container into the brew unit.

If the dispenser container is not filled because, there are no coffee beans in the bean holder; the dispenser switch is not activated. The display then shows "Fill coffee beans".

#### **4.14 Dispenser Switch**

The service mode can be used to check whether the dispenser switch is activated. With the appliance in the service mode, the top line of the display shows the switches that have been activated. The "3" indicates that the dispenser container is full / switch is actuated. Refer to Section 6 – Service Mode for further information.

## 4.15 Brew Unit Drives

Refer to Figure 4-17 – Components of the Brew Unit Drive Assembly, Water Connection and Present Switch.

When the brew unit is placed in the appliance, it locks into position. The locking mechanism switch lug (Item 3) activates the brew unit present switch (Item 4). The drive shaft (Item 6) engages with the drive shaft socket (Item 1).

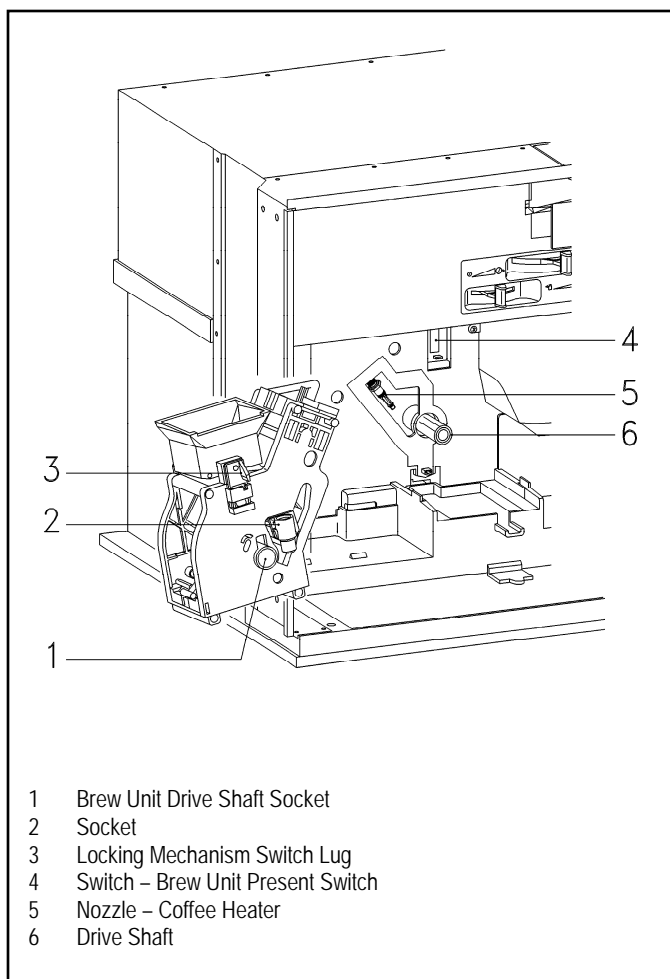
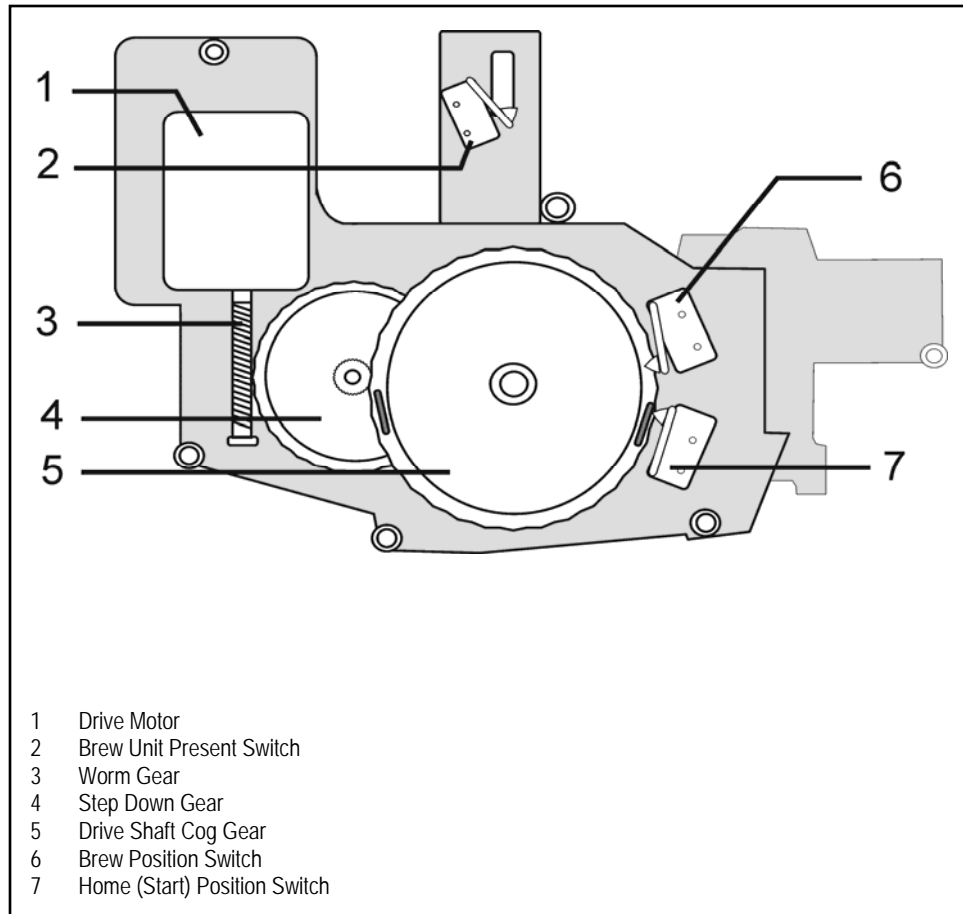

**Figure 4-17:** Components of the Brew Unit Drive Assembly, Water Connection and Present Switch

**Technical Information**

Refer to Figure 4-18 – Brew Unit Drive Assembly.

The drive motor (Item 1) is powered by the electronic and turns both the worm gear (Item 3) and the single-stage step-down gear (Item 4). The drive shaft cog gear (Item 5) has two switch actuators for the brew position switch (Item 6) and the home position switch (Item 7). Both switches are monitored by the electronic to determine the position of the brew unit.



**Figure 4-18: Brew Unit Drive Assembly**

## 4.16 Water Pump

The pump is self-priming and can develop a pressure of up to approx. 16 bar. For espresso preparation a pressure of approx. 8 bar is required so that the water can be forced through the compressed ground coffee. A further increase in pressure does not improve beverage quality.

The pump is fitted with a safety valve which opens at 16 bar system pressure. If pressure is too high, water is passed from the safety valve via a hose

The pump is connected in series with a temperature limiter. The temperature limiter interrupts the power to the pump should a high temperature develop.

## 4.17 Flow Meter

All water taken from the water container flows through the flow meter. The flow meter passes signals to the electronic unit proportional to the quantity of water passing through it.

The electronic unit then establishes the quantity of water that has flowed and stores the figure. Approx. 300 pulses from the flow meter indicate a flow of 3 ounces of water.

The electronic unit controls the required water quantity for beverage preparation and ensures that it remains constant. The service mode can be used to check the proper operation of the flow meter. See section 6 – Service Mode for further information.

## 4.18 Heaters

### **Coffee / Hot Water Heater 1R1 & 1R2**

Voltage 120V

Power rating 275W and 1090W

### **Steam Heater 2R1**

Voltage 120V

Power rating 1100W

## Technical Information

**4.19 Flow Through Heaters**

The Coffee Flow Through Heater (Figure 4-19 – Hot Water / Coffee Heater) has a large heater element; and a small heater element. The Steam Flow Heater has only one heater element (refer to figure 4-20 – Steam Heater)

Each Flow Through Heater has a Positive Thermal Coefficient (PTC) Temperature Sensor that provides a signal to the electronic unit for temperature control. In addition, a Thermostat is connected in series with the heater element. Should the temperature become too high, the Thermostat interrupts the power to the heater element.

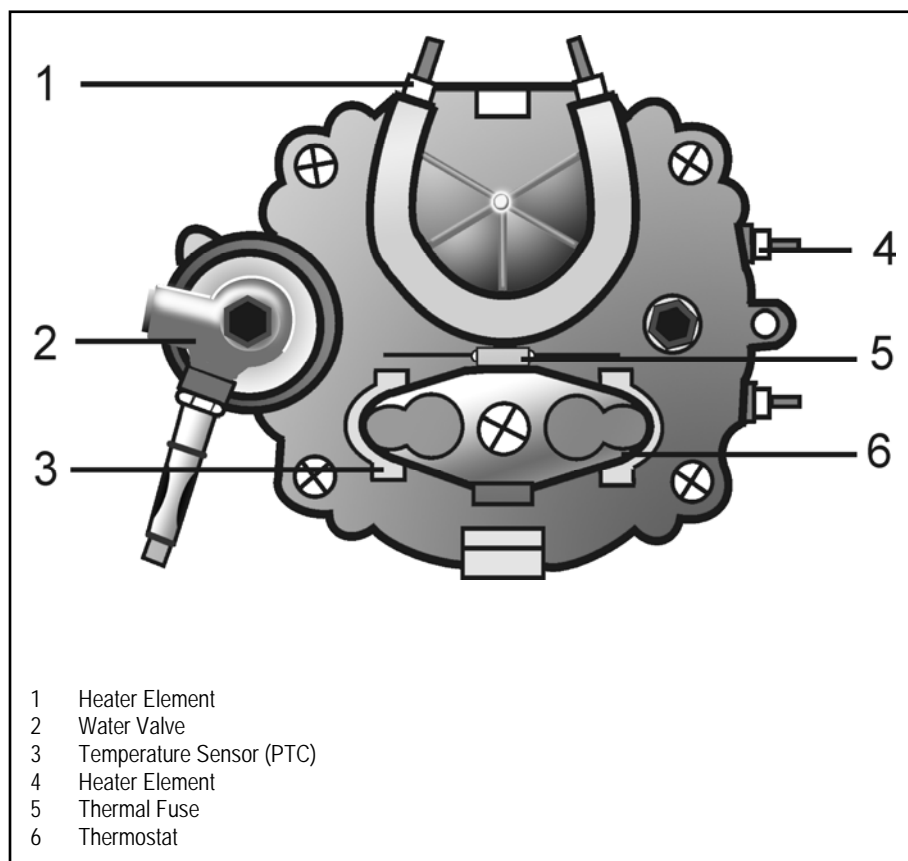
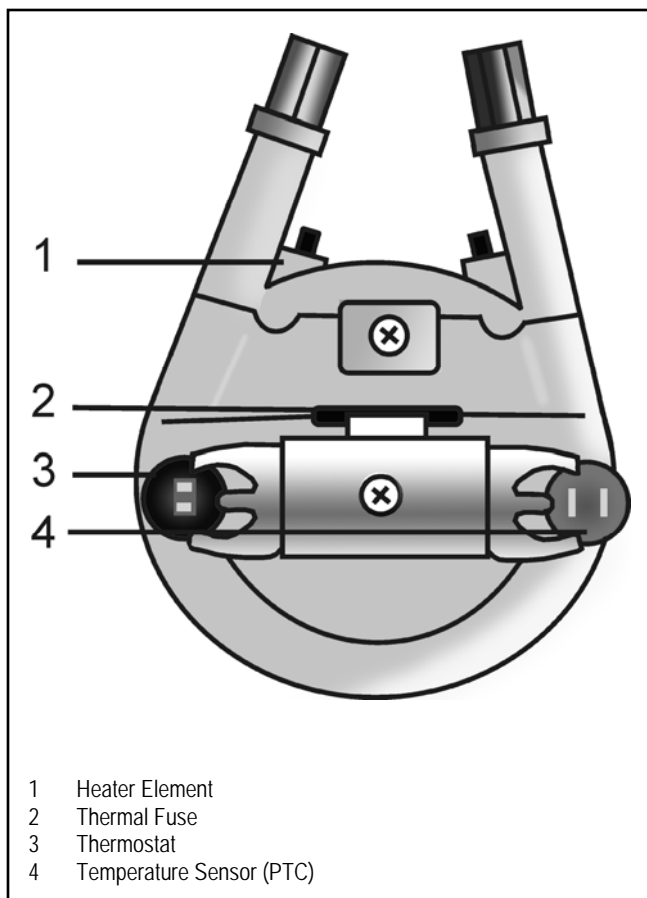

**Figure 4-19:** Hot Water / Coffee Heater



## Technical Information

As a final measure each heating circuit uses a temperature safety fuse (Figure 4-20 – Item 3). In the event the temperature became too high due to a fault, this fuse blows and cuts the power being supplied to the heater element. Should this fuse blow, the cause must be located and resolved before the fuse is replaced.



**Figure 4-20:** Steam Heater

Technical Information

**4.20 Water Path**

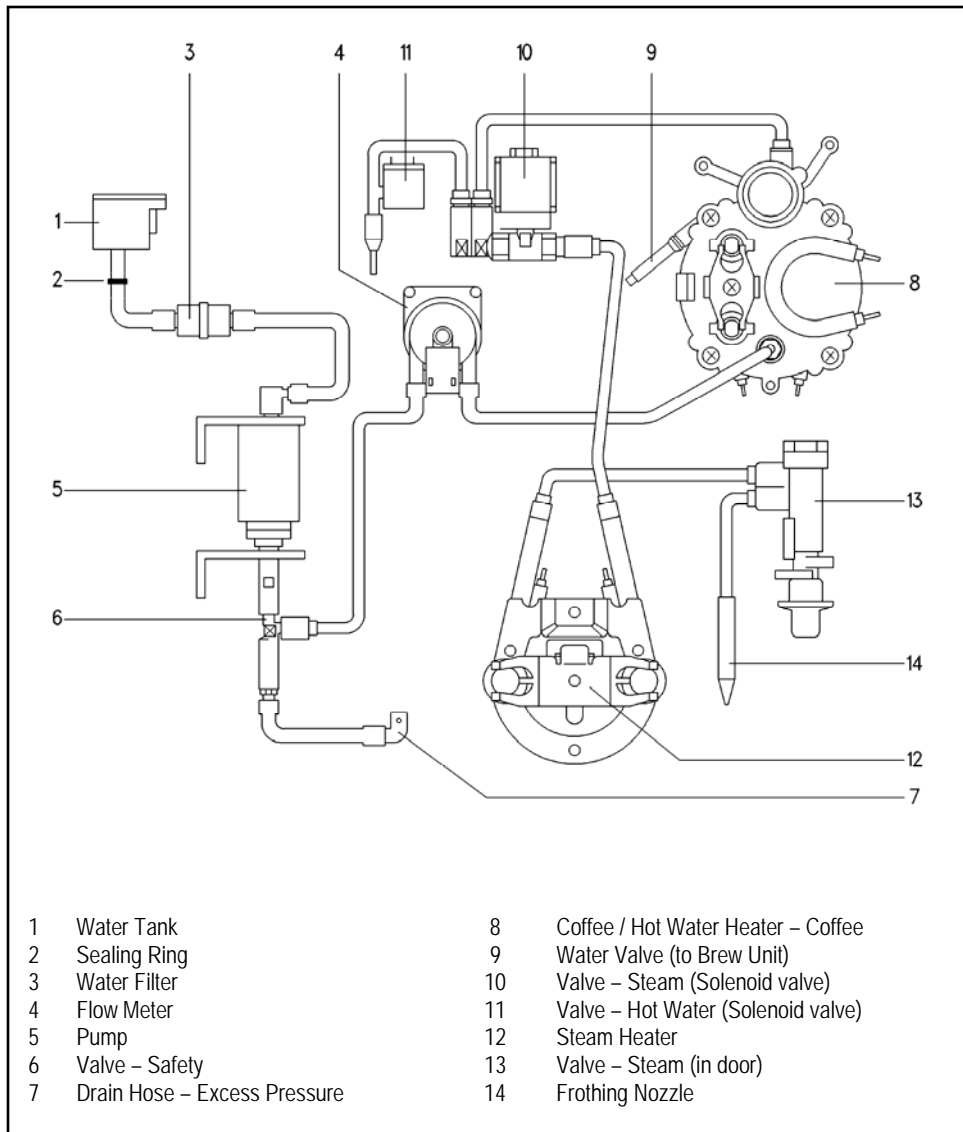

**Figure 4-21: Water Path**

**4.20.1 Water Intake**

The Pump takes in water from the water tank. (The Pump is fitted with a safety valve which opens at approx. 16 bar (232 psi) system pressure. If the pressure is too high and the safety valve opens, water is drained off via a hose to the drip tray).

**4.20.2 Water Path - Coffee**

The water is then pumped under pressure through the Flowmeter, and through the Coffee Flow Through Heater. The water is then passed through the Water Valve, into the Brew Unit.

**4.20.3 Water Path – Hot Water**

The Pump moves water under pressure through the Flowmeter, and through the Coffee Flow Through Heater. The water is then passed via the Hot Water Valve to the Hot Water Outlet.

**4.20.4 Water Path – Steam**

The pump moves water under pressure via the Flowmeter and through the Coffee Flow Through Heater. When the user selects steam; the Electronic energizes the Steam Valve. Water continues flowing through the Steam Flow Through Heater. Steam is then dispensed from the frothing nozzle.

## Technical Information

**4.21 Water Valve**

The Water Valve is attached to the output of the Coffee / Hot Water Flow Through Heater. The valve is in a normally closed position.

When the Brew Unit is driven into the brew position the valve mechanically opens and water is supplied to the Brew Unit. This connection must be air / water tight to prevent air from entering the water path, and / or leakage from the occurring.

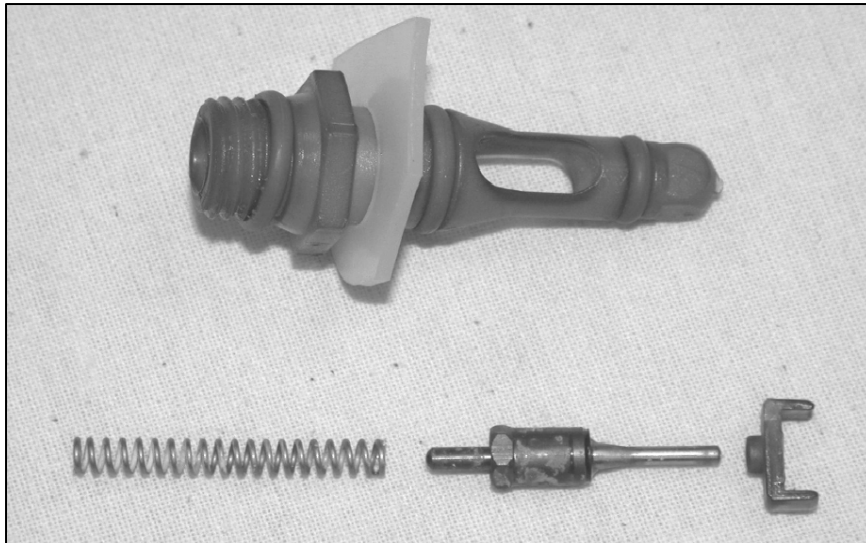

**Figure 4-22:** Water Valve (Disassembled)

The two o-rings that form the seal to the brew unit can be accessed from the front / inside area of the appliance - once the brew unit removed. To access the upper seal, the heater must be removed from the appliance. The Water Valve can be disassembled for service; parts can be replaced individually.

## 4.22 Electronic Assemblies

### 4.22.1 Power Electronic

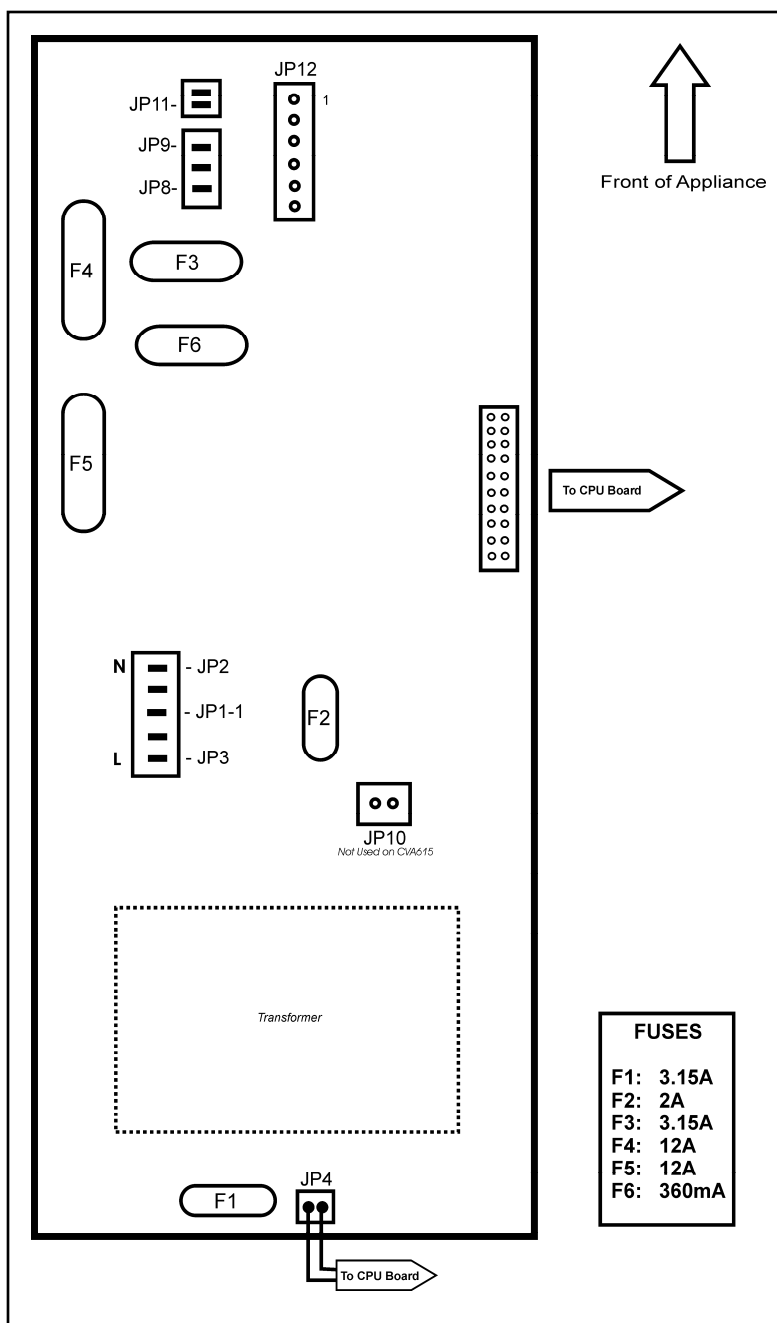

Figure 4-23: Power Electronic Board

Technical Information

4.22.2 CPU Electronic

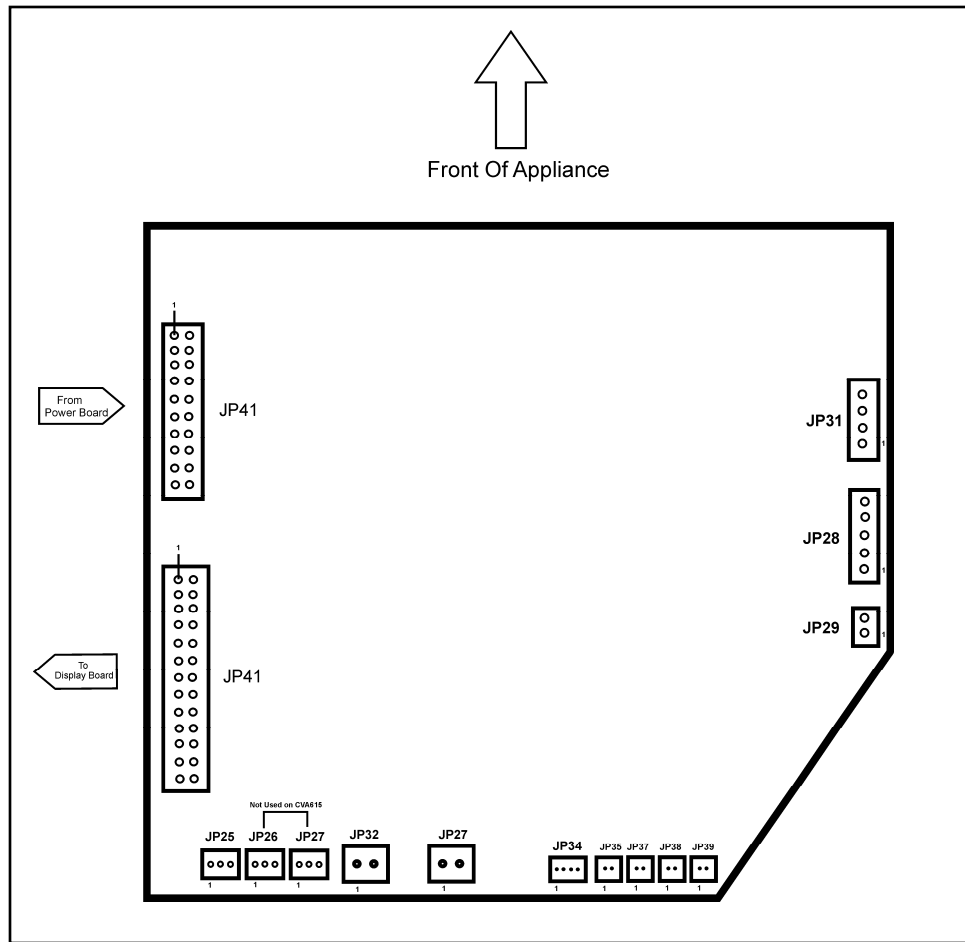

Figure 4-24: CPU (Control) Electronic

## 5.0 Service and Maintenance

**Danger!**

To avoid the risk of electrical shock, the appliance should be disconnected from the power source before any service procedures are performed.

### 5.1 Lid - Removal

1. Remove the Lid Screws, as shown in Figure 5-1.
2. Remove the lid.

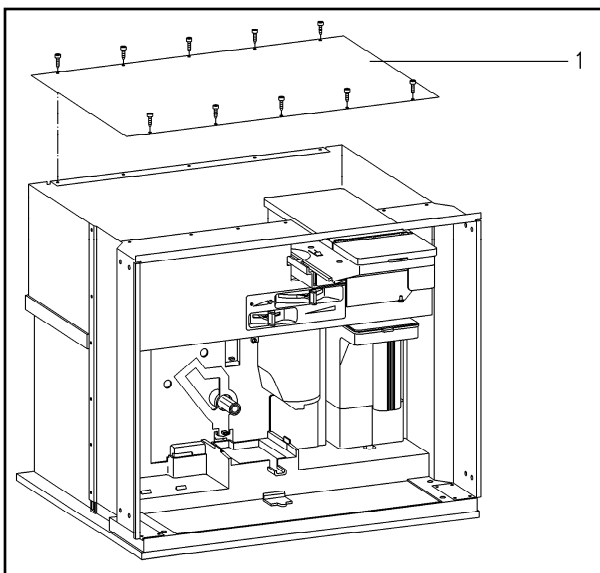
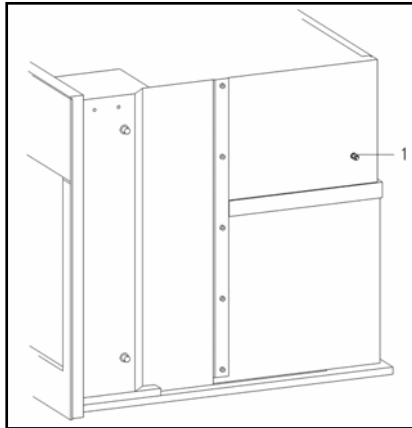

Figure 5-1: Lid with Screws

## Technical Information

**5.2 Interference Suppression Filter (Z1) - Removal**

1. Perform: Lid removal – Refer to Section 5.1.
2. Remove the Mains Filter Nut (Figure 5-2 - Item 1).
3. Remove the Filter.
4. Disconnect the Mains Filter electrical connections

**Figure 5-2:** Interference Suppression Filter (Z1) Mounting Location**5.3 Rear Panel - Removal**

1. Remove the lid – Refer to Section 5.1.
2. Remove the Mains Filter – Refer to Section 5.2.
3. Remove the fixing screws from the rear panel.
4. Disconnect the ground connection from the rear panel.
5. Remove the Rear Panel upwards.

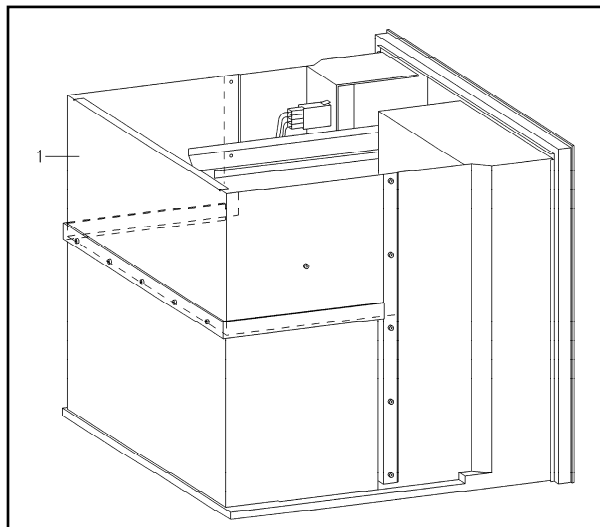
**Figure 5-3:** Rear Panel Removal



## 5.4 Adjustment Slide Switch Frame - Removal

1. Open the door.
2. Pull off the slide switch knobs.
3. Press the retaining lugs inwards with a small screwdriver (Figure 5-4).
4. Remove the frame.

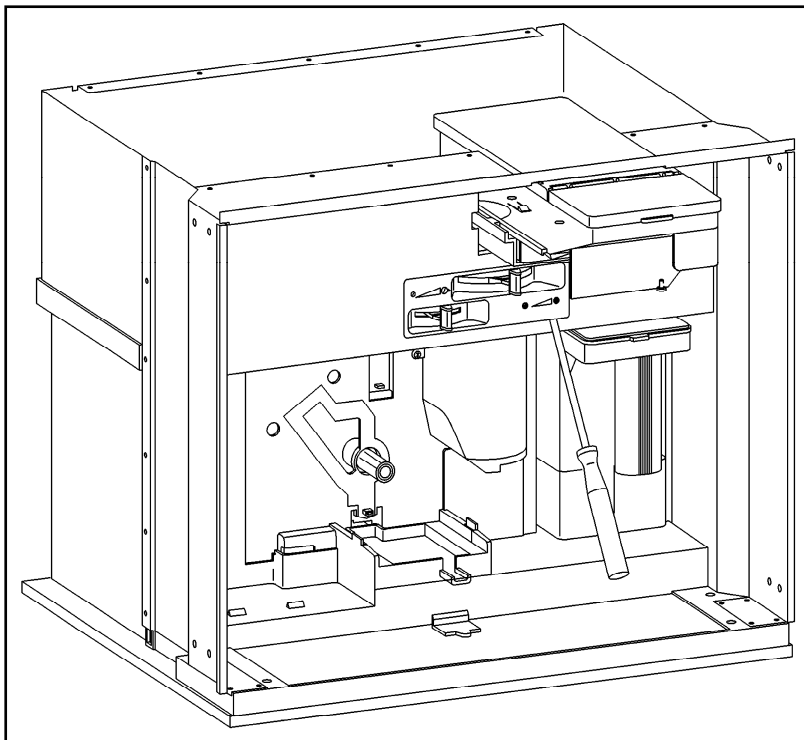

**Figure 5-4:** Removing the Adjustment Slide Switch Frame (Bezel)

## Technical Information

**5.5 Door Contact Switch (S24) - Removal**

Refer to Figure 5-5 – Door Switch.

1. Remove the lid – Refer to Section 5.1.
2. Open the door.
3. Disconnect the Door Switch Connections.
4. Press the switch retaining lugs inwards with a small screwdriver.
5. Remove the Door Switch to the front.

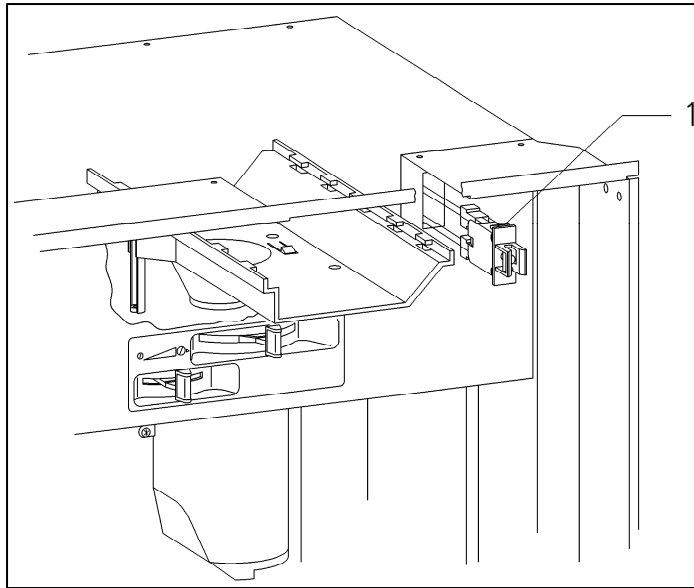

**Figure 5-5:** Door Switch (Shown with Appliance Door in Open Position)

## 5.6 Base Plate - Removal

1. Remove the Lid, Mains and Rear Panel – Refer to Sections 5.1 and 5.3.
2. Open the door.
3. Remove the Waste Container.
4. Remove the Water Tank.
5. Check if water is present in the Drip Tray with a finger through the opening under the water container.
6. If water is present, remove it using a suitable device.
7. Remove the Brew Unit – Refer to Section 5.20.
8. Remove the Coffee Beans from their container.
9. Remove the Base Plate Fixing Screws.
10. Tilt the appliance onto its rear.
11. Remove the Base Plate and disconnect the ground wire.

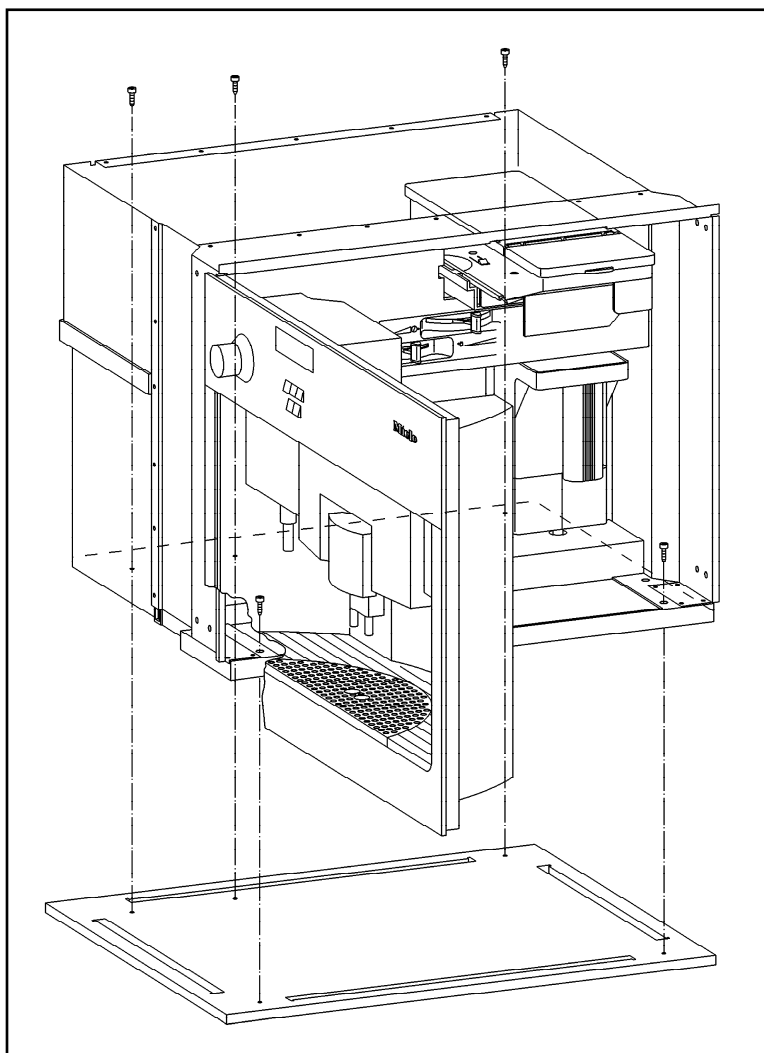
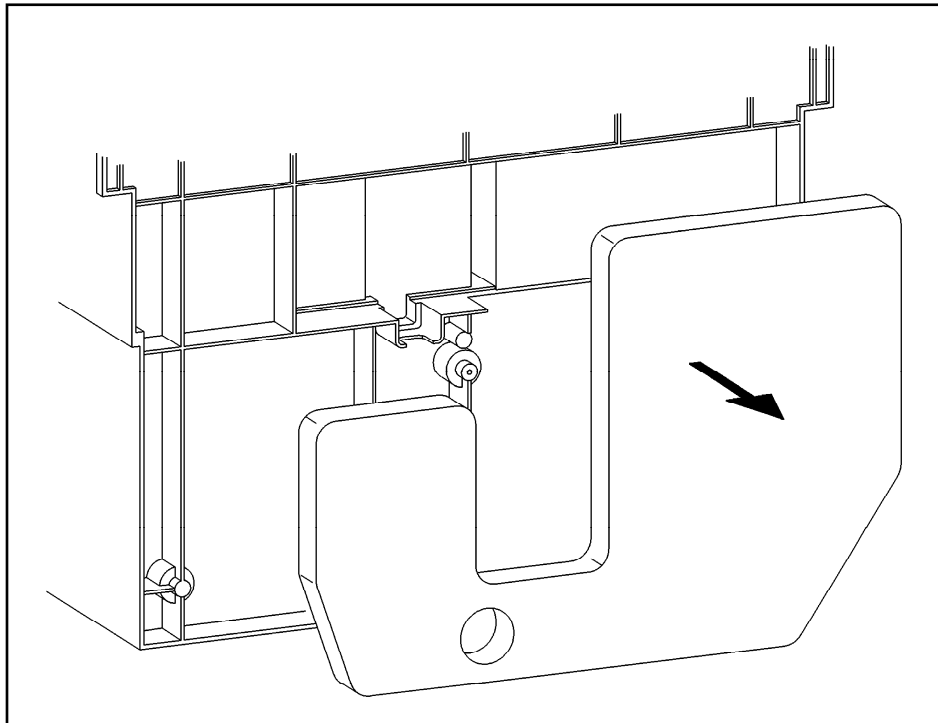

Figure 5-6: Base Plate - Removal

## Technical Information

**5.7 Drip Tray - Removal**

1. Remove the Lid, Mains and Rear Panel – Refer to Sections 5.1 and 5.3.
2. Remove the Base Plate – Refer to Section 5.6.
3. Remove the Drip Tray - Refer to Figure 5-7.

**Figure 5-7: Drip Tray Removal**

## 5.8 Overflow Switch Actuator Float - Removal

1. Remove the Lid, Mains and Rear Panel – Refer to Sections 5.1 and 5.3.
2. Remove the Base Plate – Refer to Section 5.6.

**Note:**

Ensure the float is re-installed in the same direction as when it was removed.

3. Remove the float.

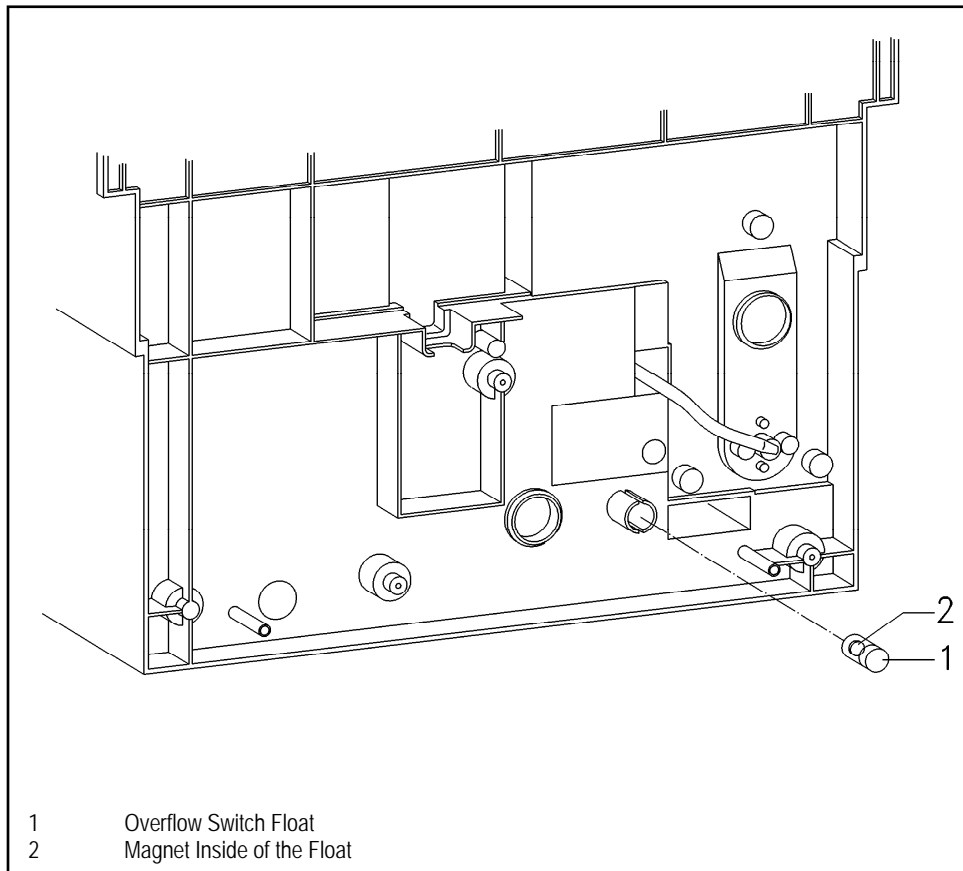
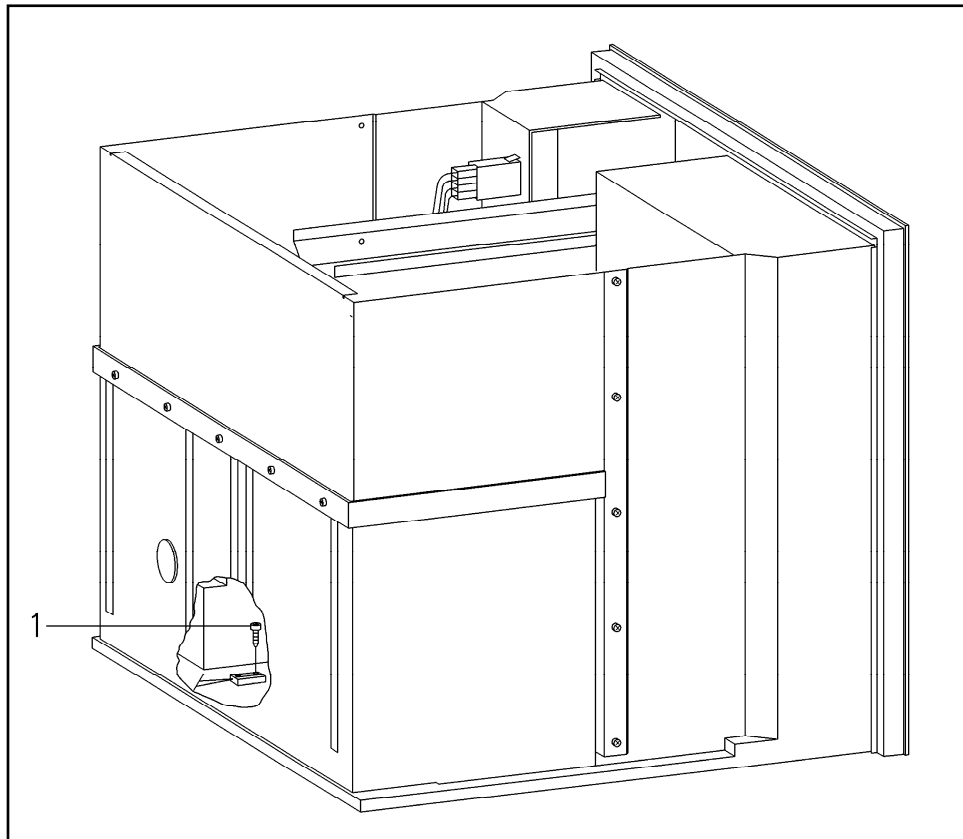

**Figure 5-8:** Overflow Switch Actuator Float

## Technical Information

**5.9 Overflow Switch (B8/3) - Removal**

1. Remove the Lid, Mains and Rear Panel – Refer to Sections 5.1 and 5.3.
2. Remove the Overflow Switch Fixing Screw (Item 1).
3. Remove the Overflow Switch.
4. Disconnect the Overflow Switch connections from the Electronic.

**Figure 5-9: Overflow Switch**

## 5.10 Rear Door Panel - Removal

1. Open the door.
2. Remove the Upper Rear Panel Fixing Screws (Item 1).
3. Remove the Lower Rear Panel Fixing Screws (Item 2).

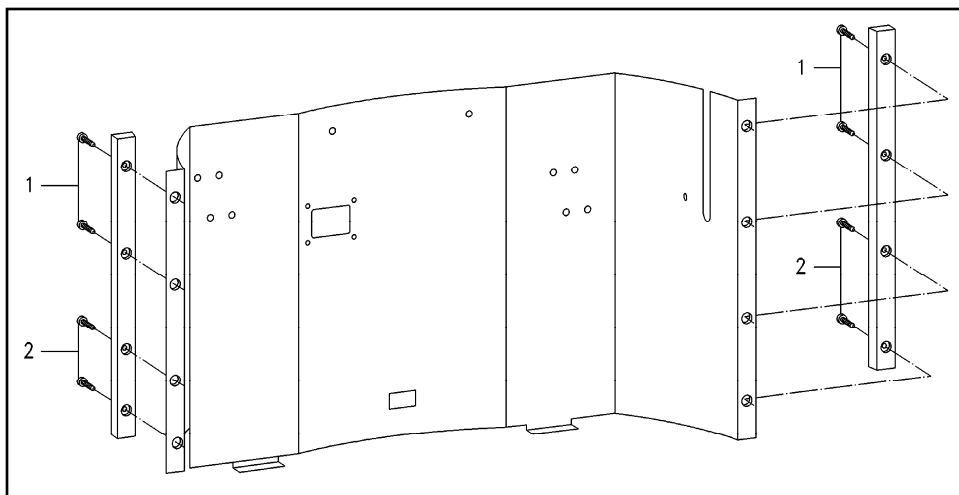
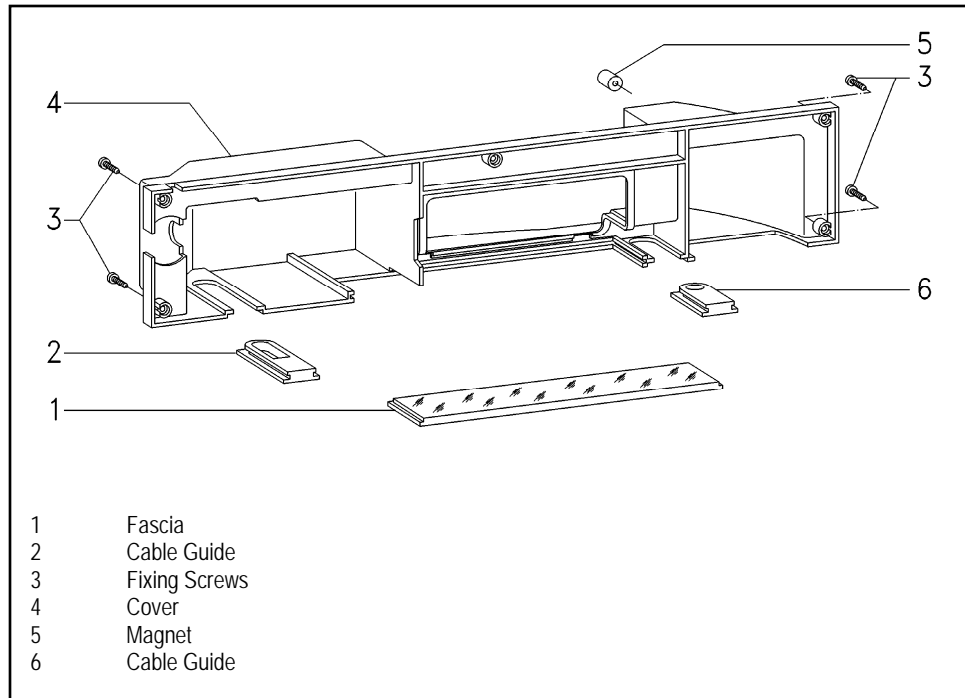

Figure 5-10: Rear Door Panel - Removal

## Technical Information

**5.11 Fascia Panel Cover - Removal**

1. Open the door.
2. Remove the Rear Door Panel – Refer to Section 5.10.
3. Remove the Cover Fixing Screws (Item 3).
4. Remove the cover.

**Figure 5-11: Fascia Panel Cover Assembly**



## 5.12 Selector Switch - Removal

1. Open the door.
2. Remove the Rear Door Panel and Fascia Panel Cover – Refer to Section 5.10 and 5.11. – Refer to Section 5.10 and 5.11.
3. Unplug the electrical connection from the Selector Switch.
4. Remove the Switch Knob (Item 9).
5. Remove the Selector Switch with its housing from the Fascia.
6. Remove the Selector Switch Fixing Screws.
7. Remove the Selector Switch from its Housing.

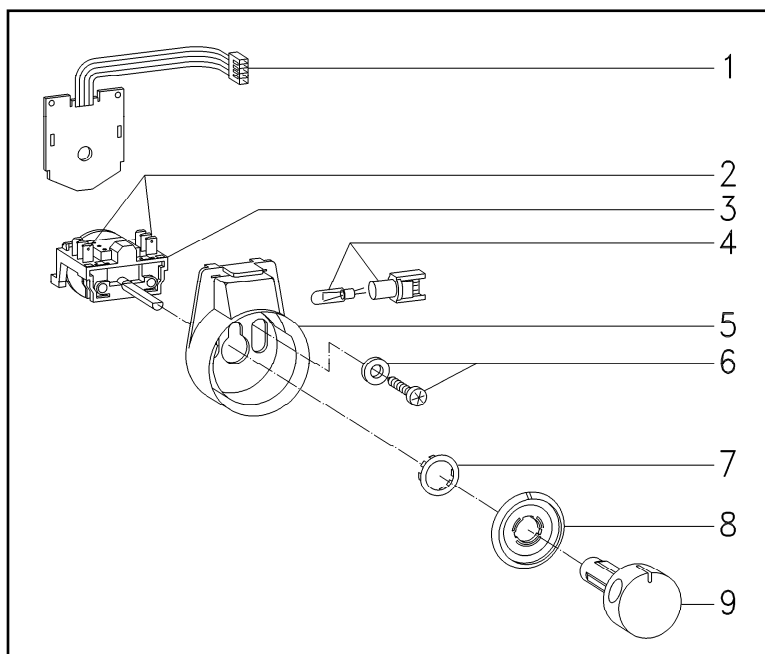
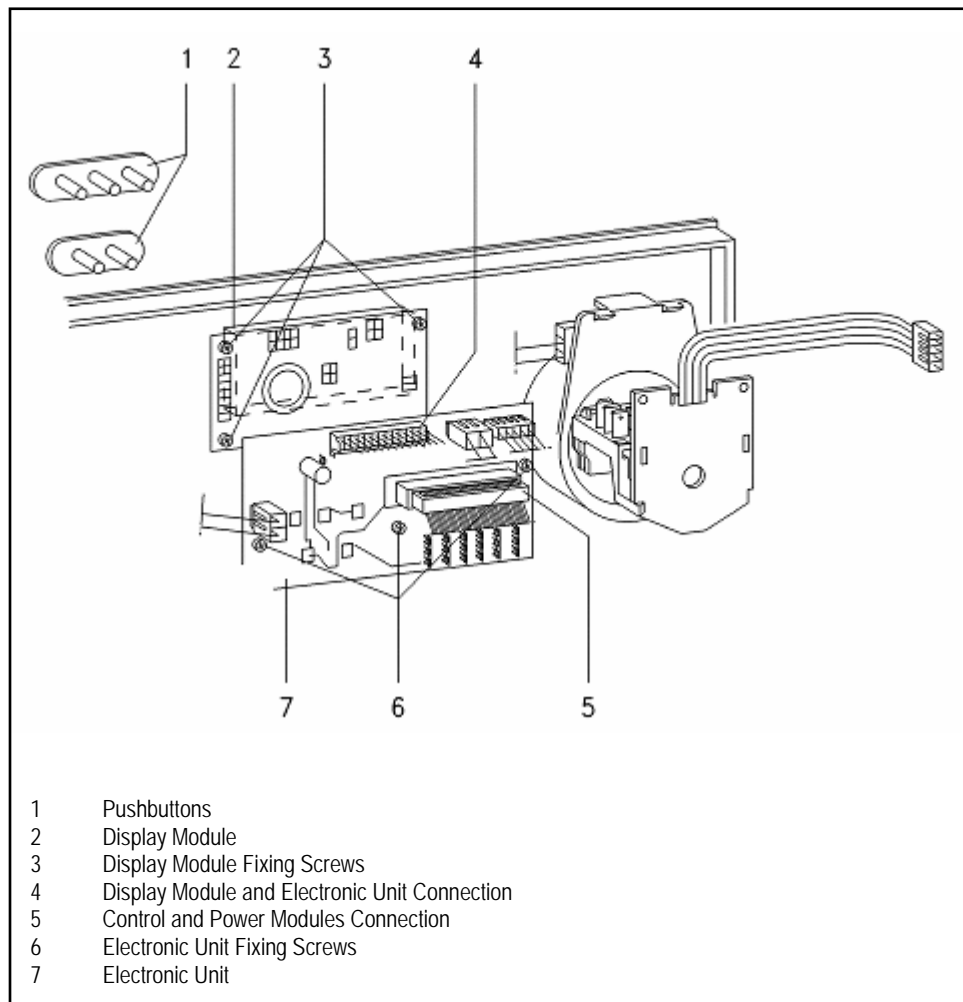

Figure 5-12: Selector Switch

## Technical Information

**5.13 Display Module Electronic - Removal**

1. Open the door.
2. Remove the Rear Door Panel and Fascia Panel Cover – Refer to Section 5.10 and 5.11. – Refer to Section 5.10 and 5.11.
3. Pull off the Pushbutton Knobs (Item 1).
4. Disconnect the Connections from the Electronic (Item 7).
5. Remove the Electronic Unit Fixing Screws (Item 6).
6. Remove the Electronic Unit.
7. Remove the Display Module Fixing Screws (Item 3).

**Figure 5-13: Rear View of Front Door with Rear Panel Removed**

## 5.14 Coffee Dispensing Nozzle - Removal

1. Open the door.
2. Remove the Grille and Drip Tray from the door – Refer to Section 5.7.
3. Remove the fixing screws from the white panel under and behind the nozzle.
4. Remove the white panel.

**Note:**

The two screws for the moveable coffee-dispensing nozzle are on the rear of the dispenser unit.

5. Remove the 2 screws from the Coffee-Dispensing Nozzle by hand.
6. Pull out the hose (Item 6), from the outlet, (Item 7).
7. Pull out the moveable coffee dispensing nozzle (Item 9), to its end stop.
8. Unclip the outlet and remove it.
9. Remove the moveable coffee dispensing nozzle.

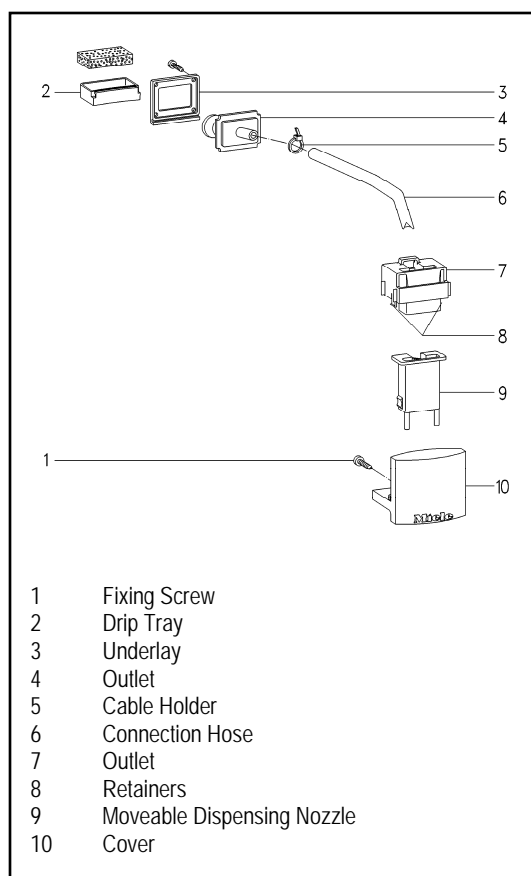

**Figure 5-14:** Components of the Coffee Dispensing Nozzle

## Technical Information

**5.15 Coffee Dispensing Nozzle - Installation**

Refer to Figure 5-14 – Components of the Coffee Dispensing Nozzle.

1. Slide the outlet (Item 7), onto the connection hose (Item 6).
2. Position the moveable coffee dispensing nozzle, (Item 9), in the cover (Item 10).
3. Clip the outlet (Item 7), in the cover (Item 10).

**Note:**

The two screws for the coffee dispensing nozzle should be tightened by hand only as they can easily be over tightened.

4. Fit the Coffee Dispensing Nozzle in the frame.
5. Install the white panel and screws.

## 5.16 Steam Valve and Steam Valve Switch (S79) - Removal

1. Open the door.
2. Remove the Rear Door Panel and Fascia Panel Cover – Refer to Section 5.10 and 5.11. – Refer to Section 5.10 and 5.11.
3. Pull off the Switch Knob (Item 8).
4. Remove the holder fixing screws (Item 3).
5. Remove the holder.
6. Remove the Steam Valve Switch screws (Item 10).
7. Remove the Steam Valve Switch.
8. Disconnect the electrical connections.

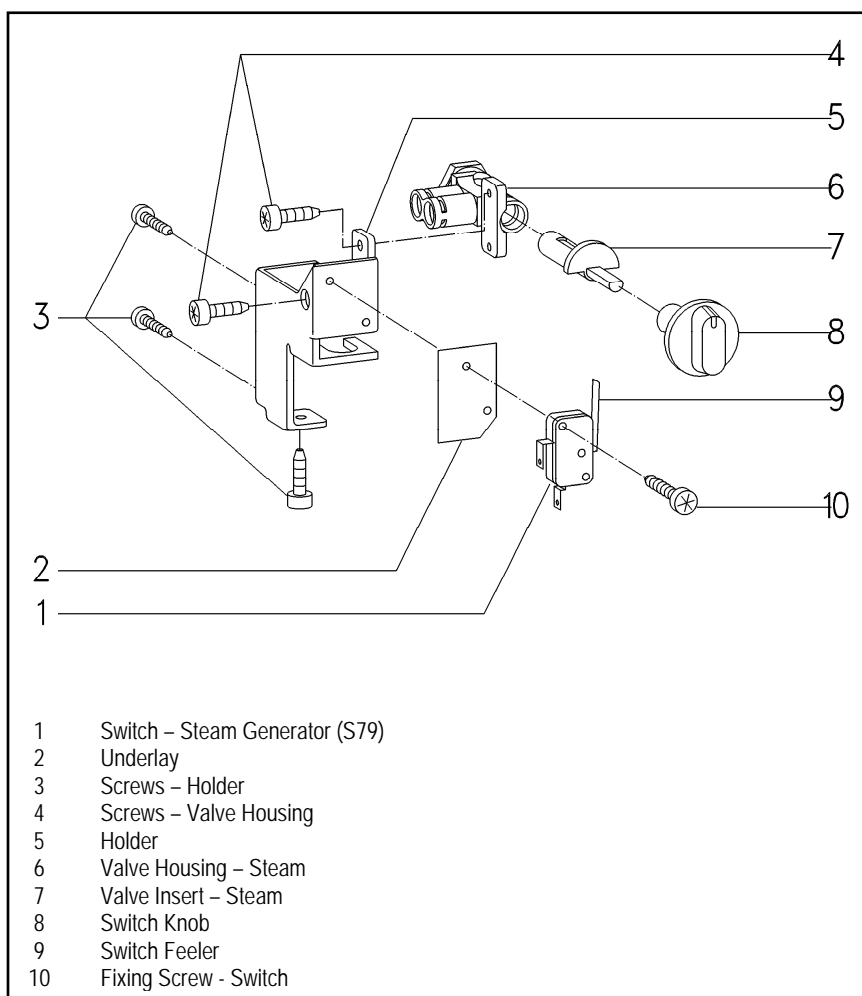
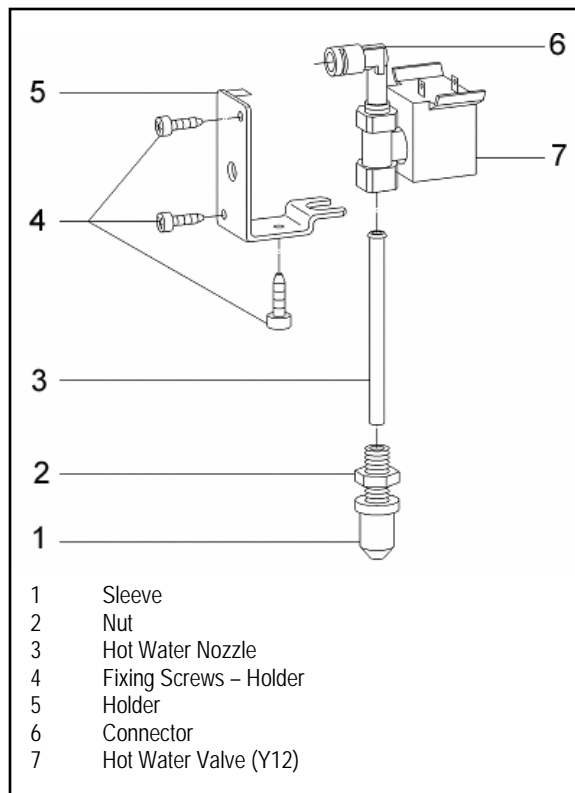

**Figure 5-15:** Components of Steam Valve and Steam Valve Switch

## Technical Information

**5.17 Hot Water Nozzle - Removal**

1. Open the door.
2. Remove the Rear Door Panel and Fascia Panel Cover – Refer to Section 5.10 and 5.11.
3. Loosen the nut (Item 2).
4. Remove the holder (Item 5).
5. Unscrew the sleeve, (Item 1) from the connector (Item 6).
6. Pull out the Hot Water Nozzle (Item 3), from the connector.

**Figure 5-16: Hot Water Valve Components****5.18 Hot Water Valve (Y12) - Removal**

Refer to Figure 5-16.

1. Open the door.
2. Remove the Rear Door Panel and Fascia Panel Cover – Refer to Section 5.10 and 5.11.
3. Disconnect the electrical connection (Item 7).
4. Loosen the Hot Water Valve Nuts.
5. Pull out the Hot Water Valve from the connector (Item 6).

## 5.19 Checking Temperature at Coffee Dispenser

### Warning!

To avoid adverse operating conditions:

- Do not deviate from the procedure.
- Do not change any other settings or values during this procedure.

1. Set the grinding grade to medium.
2. Set the coffee quantity to medium.
3. Set the Medium Coffee temperature to medium (standard setting).
4. Turn off the appliance.
5. Press and hold the **Small Coffee Button**, **Large Coffee Button** and the **Hot Water Button**. Turn the Selector Switch to the “**On with Light**” position.

The following is displayed:

**LANGUAGE**  
**RINSING**

6. Press the **Medium Coffee Button** 12 times.

The following is displayed:

**DIAGNOSIS**  
**LANGUAGE**

7. Press the **Small Coffee Button** 1 time.
8. Press the **Medium Coffee Button** 2 times.

The following is displayed:

**1 COFFEE**  
**N°IMPULS. 350**

**Note:**  
This value may vary

9. Observe the numeric value in the lower right corner of the display.
  - If a value of “350” is displayed; proceed to step 14.
  - If the value is not 350; proceed to step 10.
10. Press the **Small Coffee Button** 1 time. A blinking box will appear at the end of the numeric value.

---

**Technical Information**

11. Set the value to “350” as follows:

- Press the Large Coffee Button to increase the value.
- Press the Medium Coffee Button to decrease the value.

**Note:**

Each press of the Large or Medium Coffee will change the displayed value by 1. (i.e. 347...348...349...350)

12. Press the Small Coffee Button 1 time to store the value.

13. Turn the selector switch to the “**Off**” position.

14. Turn the selector switch to the On or On with Light position.

15. Prepare 4 coffees (medium size) one after the other.

16. When the fourth coffee is being dispensed, hold the sensor probe directly in the flow of coffee. The temperature at the coffee dispenser should be 171°F - 194°F.

## 5.20 Brew Unit – Removal (in Start/Home Position)

1. Open the door.
2. Remove the Waste Container.
3. Hold the handle and press on the part marked PRESS.
4. Gently pull outward on the Brew Unit to remove it from the appliance.



## 5.21 Brew Unit – Removal (NOT in Start/Home Position)

**Warning!**

This procedure will remove the brew unit from the appliance without damages. However, after the brew unit is removed, the drives must be carefully inspected (and repaired if necessary) then placed into the start (home) position via the service mode.

Before proceeding close the front door, turn the power on to initiate a drive reset during the start-up sequence.

Once “Ready...” is displayed; open the front door and attempt to Remove the Brew Unit – Refer to Section 5.20. If the brew unit still cannot be easily removed, perform the following:

Refer to Figures 5-17 – Brew Unit and 5-18 – Brew Unit Connection Socket Retaining Screw and Locking Tab on the next page...

1. Open front door - Remove the Waste Container.
2. Locate the Philips screw (Figure 5-17, Item 2).
3. Remove the Philips screw.
4. Use a small flat tip screwdriver to left up on the locking tab (Figure 5-18).
5. Grasp the brew unit handle and pull the brew unit out till the connection socket on the brew unit (Figure 5-17, Item 1) unsnaps from the brew unit and remains inside the appliance attached to the water nozzle.
6. Remove the Brew Unit – Refer to Section 5.20.
7. Slide the connection down to remove it from the appliance.
8. Re-install the connection socket to the Brew Unit.
9. Carefully inspect the drives for defects.
10. Test the Home Position Switch and Brewing Position Switch for proper operation.

Technical Information

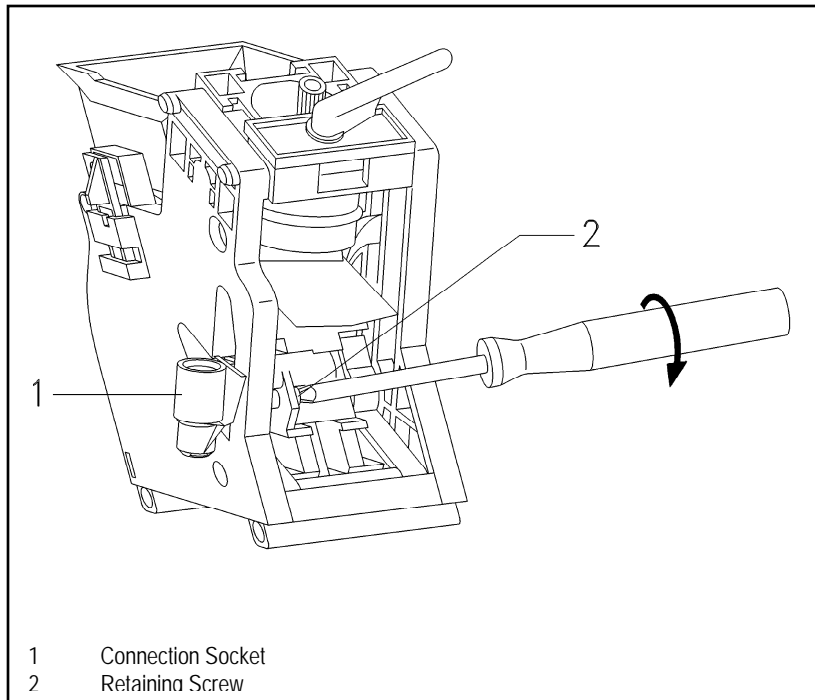

**Figure 5-17: Brew Unit**

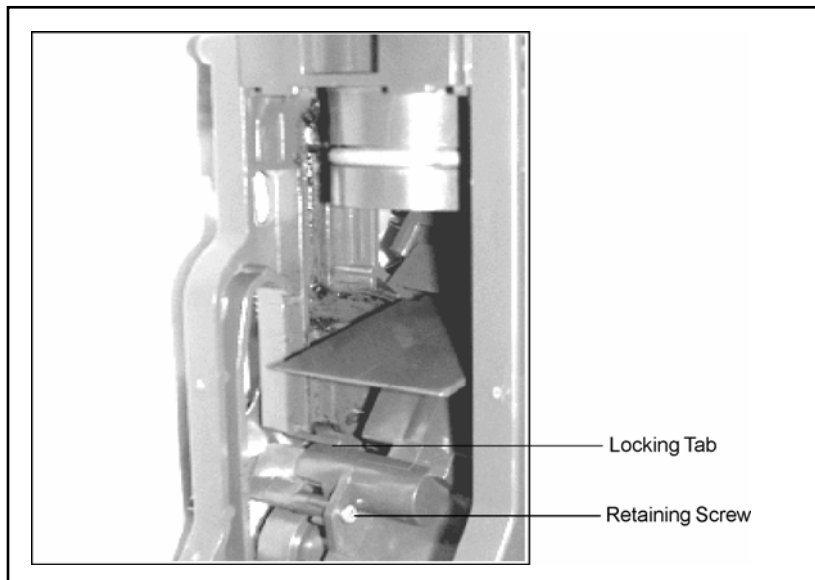

**Figure 5-18: Brew Unit Connection Socket Retaining Screw and Locking Tab**

## 5.22 Brew Unit - Installation

1. Remove the Waste Container.
2. Slide the Brew Unit into position in the appliance until the locking mechanism engages with the mounting plate.

**Note:**

Do not press the part marked PRESS during the installation of the brew unit.

## 5.23 Brew Unit – Cleaning Procedure

**Note:**

- Clean the Brew Unit by hand only; it **SHOULD NOT** be cleaned in a dishwasher.
- Lubricate the Brew Unit with silicon every 500 cups.

1. Remove the Waste Container.

**Note:**

The Brew Unit can only be removed after the Waste Container has been removed from the appliance.

2. Grasp the brew unit by the handle and press with the thumb on "PRESS". (Figure 5-19, Item 1).

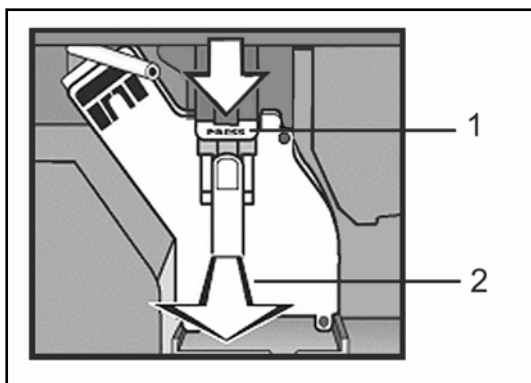
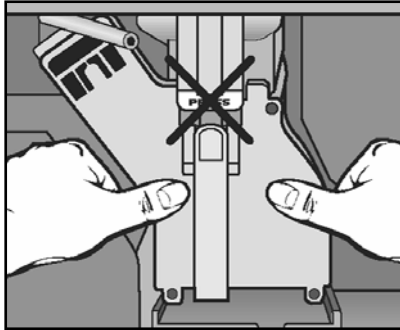

**Figure 5-19:** Brew Unit – Removal for Cleaning

3. Pull outward to remove the Brew Unit (Figure 5-19, Item 2).
4. Clean the Brew Unit thoroughly under running warm water without detergent.

**Technical Information**

5. Rub away coffee residues from the steel filters with a sponge.
6. Dry the funnel to prevent ground coffee from sticking.
7. After cleaning press "PRESS".
8. Remove the Waste Container (if re-installed).



**Figure 5-20:** Brew Unit Installation

9. Push the brew unit in the track straight into the appliance without pressing "PRESS" until it clicks in place (refer to Figure 5-20 – Brew Unit Installation).

## 5.24 Brew Unit – Filter Cleaning

1. Remove the Brew Unit – Refer to Section 5.20.
2. Wipe away coffee residues from the steel filter in the funnel of the brew unit with a sponge.
3. The filters can be removed for thorough cleaning.
4. Fit a 5mm allen wrench to the connection point in the brew unit. Turn counterclockwise while supporting the chrome filter from below. Remove the filter by lifting it from the brew unit.
5. Access the second filter by placing a long shaft Philips Screwdriver through the center of the funnel and remove the screw in the center of the filter.
6. Manually move the brew unit into the “brew position”.
7. Turn brew upside down – filter will fall out.
8. Clean both sides of the filter with hot water and dry.
9. Re-install the second filter back in position.
10. Manually move the Brew Unit to the “home position”
11. Re-install the Philips screw in the center of the filter.
12. Return the first filter to the brew unit and secure by turning the allen wrench clockwise.

## 5.25 Brew Unit – Degreasing via the Rinse Cycle

**Note:**

The natural oil found in coffee can cause the Brew Unit to clog. The message “Rinsing Cycle” will flash in the message window after 500 cups to remind you to clean the unit using “cleaning tablets”.

These specialty-cleaning tablets can be purchased from Miele.

1. Remove the Waste Container.
2. Remove the Brew Unit and put the detergent tablet in the brew unit funnel.

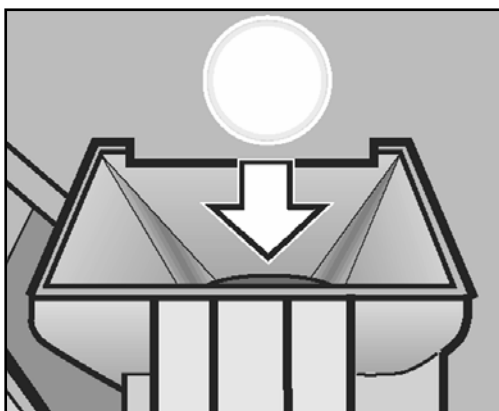

**Figure 5-21:** Cleaning Tablet being Placed into the Brew Unit Funnel

3. Return the brew unit and waste unit to the appliance and close the door.
4. Set a 25 oz. container under the coffee dispensers.
5. Press the rinse/ pre-warm button. (The unit must be pre-heated and ready to use otherwise the button will not respond.)
6. The display will read:

<b>RINSING</b>	<b>*</b>
<b>RINSING CYCLE</b>	

7. Press ▼ to select “Rinsing Cycle” with the asterisk.

**Technical Information**

8. Press ENTER. The display will read:

**RINSING CYCLE**

A small amount of water will flow out the coffee dispensers. After a pause, more water will flow out. This process will run 4 times, dispensing 2 cups (17 oz) of hot water. The whole process lasts about 5 minutes.

At the end of the cleaning cycle the display will read:

**SELECT PRODUCT  
READY FOR USE**

The Brew Unit is now clean and ready to use.

## 5.26 Brew Unit - Lubrication

1. Remove the Brew Unit – Refer to Section 5.20.

**Note:**

Check that the Brew Unit is in the basic position with the funnel slightly lifted and the socket in vertical position.

2. Refer to Figure 5-22, lubricate the following:

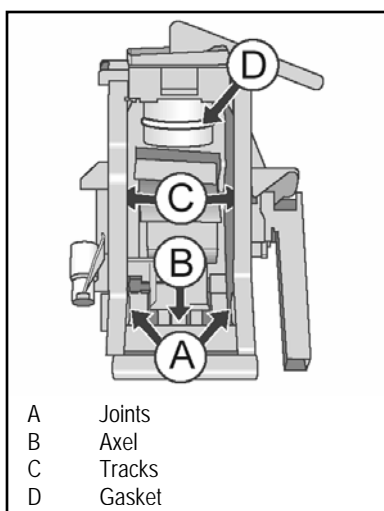

**Figure 5-22:** Brew Unit Lubrication Points

3. Refer to Figure 5-23, lubricate the following:

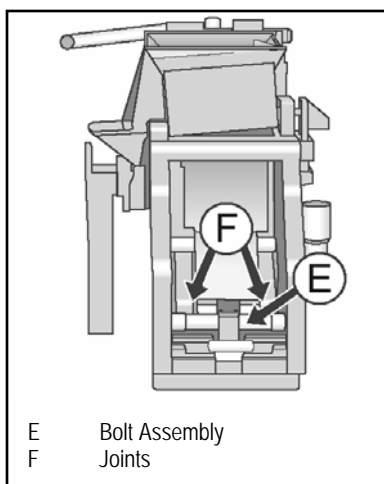

**Figure 5-23:** Brew Unit Lubrication Points

4. Return the brew unit into the appliance.

## Technical Information

**5.27 Brew Unit – Manual Reset to “Home Position” (with Brew Unit Not Installed in Appliance)**

Refer to Figure 5-24.

1. Press on the latch A; and press the funnel down B.
2. Push the connection piece to the far left position C.
3. Press "PRESS" once.

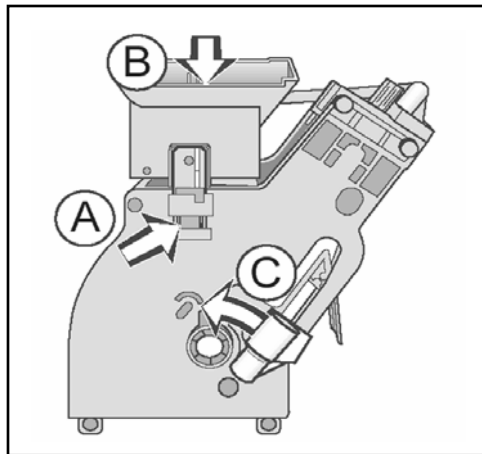

**Figure 5-24:** Moving the Brew Unit to “Home Position”

4. The “Home” position (Figure 5-25) after resetting the Brew Unit. The Brew Unit can now be installed into the appliance.

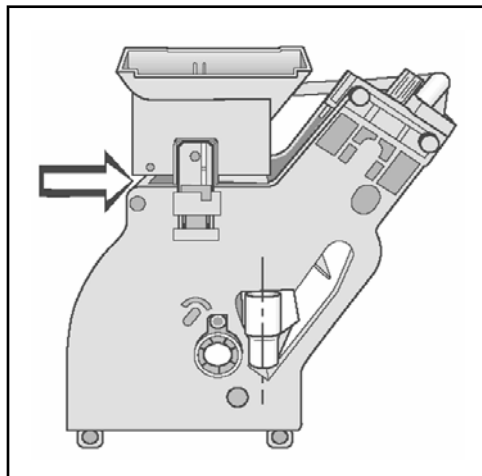

**Figure 5-25:** Brew Unit in Reset Position



## 5.28 Brew Unit Creamer Valve - Removal

1. Remove the Brew Unit – Refer to Section 5.20.
2. Remove the output fixing screws.
3. Remove the output.
4. Remove the spring and Creamer Valve.

## 5.29 Brew Unit Handle - Removal

1. Remove the Brew Unit from the appliance – Refer to Section 5.20.
2. Press the handle retaining lugs inwards (Figure 5-26).
3. Remove the handle.

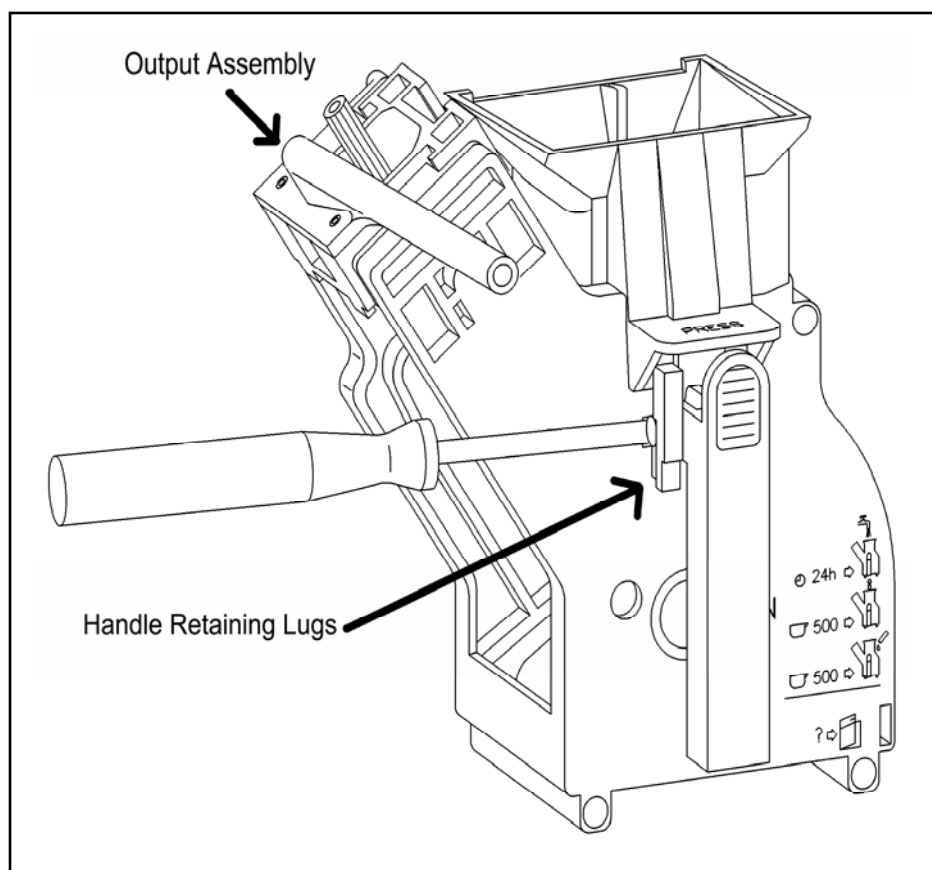

**Figure 5-26:** Brew Unit – Highlighting the Output Assembly (Covering the Cream Valve) and Retaining Lugs for Securing the Handle to the Brew Unit Body

## Technical Information

**5.30 Brew Unit Funnel - Removal**

1. Remove the Brew Unit from the appliance – Refer to Section 5.20.
2. Press the Funnel Locking Lug (Figure 27, Item 1), so that the funnel is no longer raised.
3. Lever the funnel upwards out of its holder (Figure 5-28).

**Note:**

When installing the Funnel, ensure the spring (Figure 5-28, Item 1) is seated correctly.

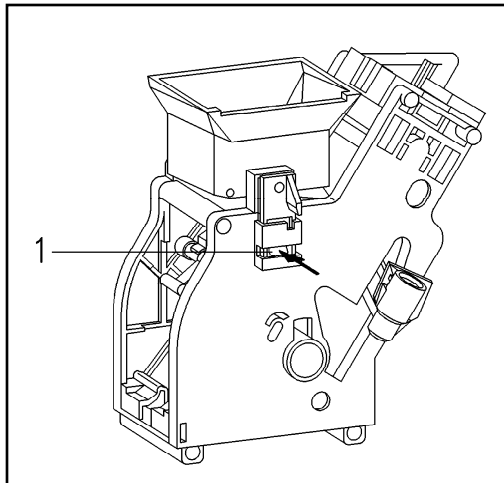

**Figure 5-27:** Rear of the Brew Unit, Highlighting the Funnel Lock

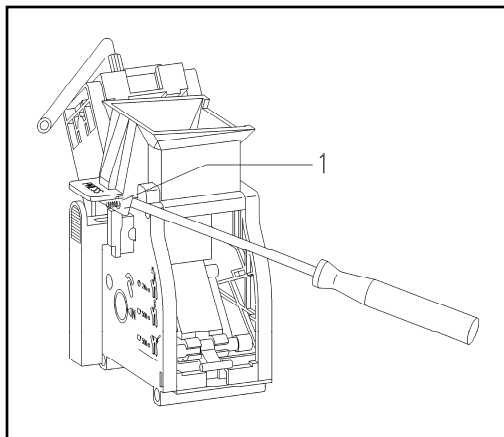

**Figure 5-28:** Front of Brew Unit, Showing Spring Location and Holder

### 5.31 Brew Unit Ram - Service

1. Remove the Brew Unit from the appliance – Refer to Section 5.20.
2. Remove the funnel.
3. Remove the bottom filter screw and filter (Figure 5-29, Items 1 and 2).

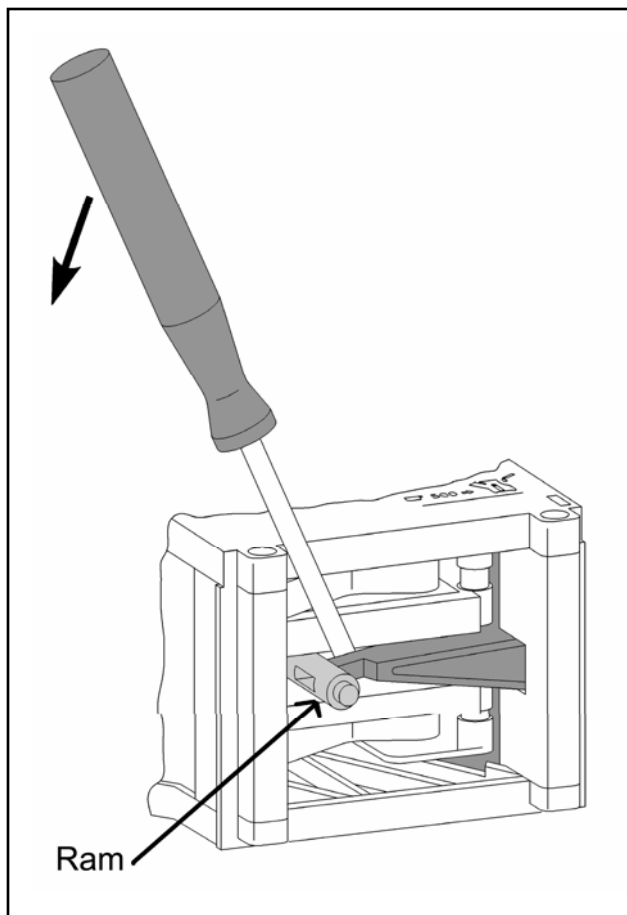
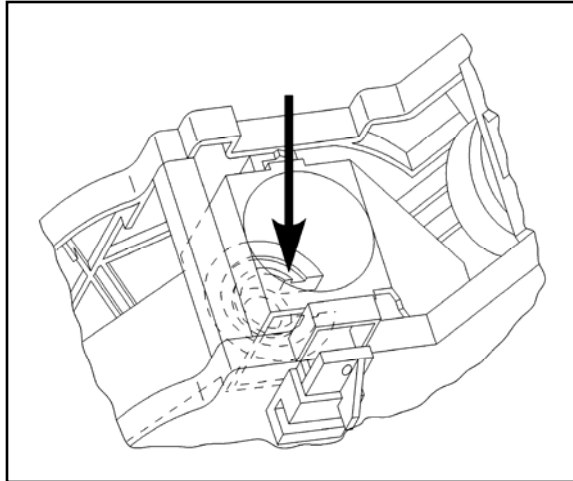

**Figure 5-29:** Releasing the Ram from the Bottom of the Brew Unit

4. Unclip the lever from the ram.
5. Pull the ram outward to remove from the Brew Unit.

**Technical Information**

6. Clean the brewing chamber (Figure 5-30), ram and bottom filter by hand with warm water without detergent, then dry.
7. Apply silicone grease to the ram lubrication points.



**Figure 5-30:** Brewing Unit Chamber Inside the Brew Unit Assembly

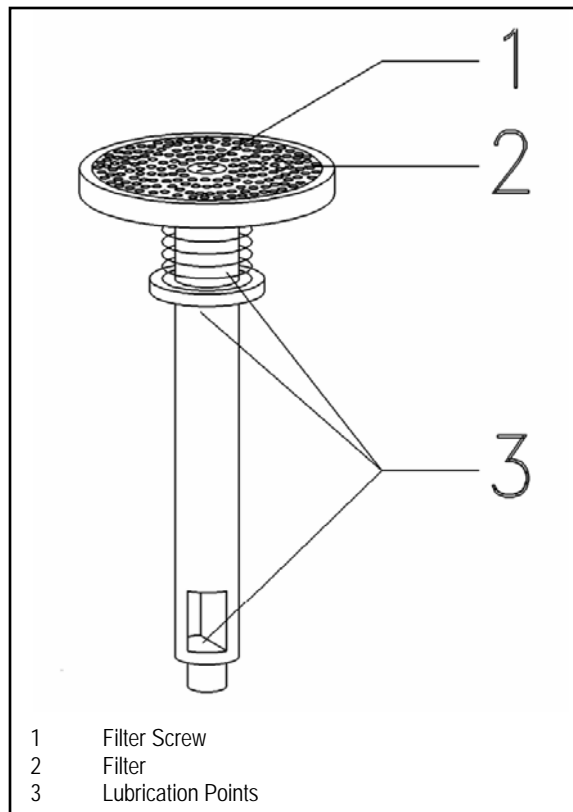

**Figure 5-31:** Ram Assembly

## 5.32 Brew Unit Drives - Service

1. Disconnect the power. Allow the appliance to cool.
2. Remove the Brew Unit from the appliance – Refer to Section 5.20.
3. Remove the Waste Container from the appliance.
4. Remove the Beans Container and Beans Container Guide – Refer to Section 5.36 and 5.37.
5. Remove the lid – Refer to Section 5.1.
6. Remove the Rear Panel – Refer to Section 5.2.

**Important!**

Before unplugging any connections, label the plugs and connectors to ensure the wiring is returned to the correct locations during reassembly.

7. Disconnect L1 and N from the Door Switch to the Interference Suppressor
8. Disconnect the ground wires from the Cord Socket / Terminal Block.
9. Disconnect the following connections from the Power Electronic:
  - JP2
  - JP12
  - JP4
10. Disconnect the following connections from the CPU Electronic:
  - JP34
  - JP35
  - JP25
  - JP39
  - JP41 (Ribbon Cable)
11. Disconnect the ground connection from the Dispenser Solenoid.
12. Disconnect the ground connection from the Hot Water Heater.
13. Remove the CPU Electronic (with its mounting assembly) and position toward the rear outside of the appliance.
14. Remove the Steam Heater from its mount and position it outside the appliance.
15. Disconnect the Water Intake Connection to the Hot Water / Coffee Heater

## Technical Information

16. Refer to Figure 5-32 – Front Plate Assembly with Retaining Screws Locations. Remove the two Hot Water / Coffee Heater Screws; Separate the Heater from its mounting position.
17. Refer to Figure 5-32. Remove the two “Cosmetic Fixing” screws. Remove the Cosmetic Fixing from inside the appliance.

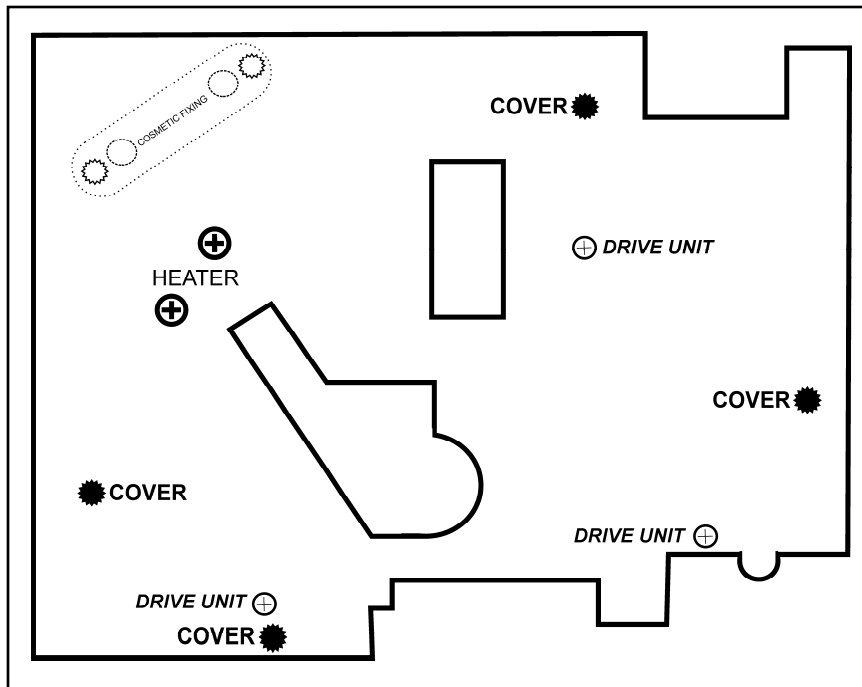

**Figure 5-32:** Front Plate Assembly with Retaining Screw Locations

18. Refer to Figure 5-33 – Grinder Retaining Screws and Figure 5-34 – Grinder Retaining Nuts.
19. Remove the two screws and nuts that secure the Grinder Plate Assembly to the top of the Front Plate Assembly.

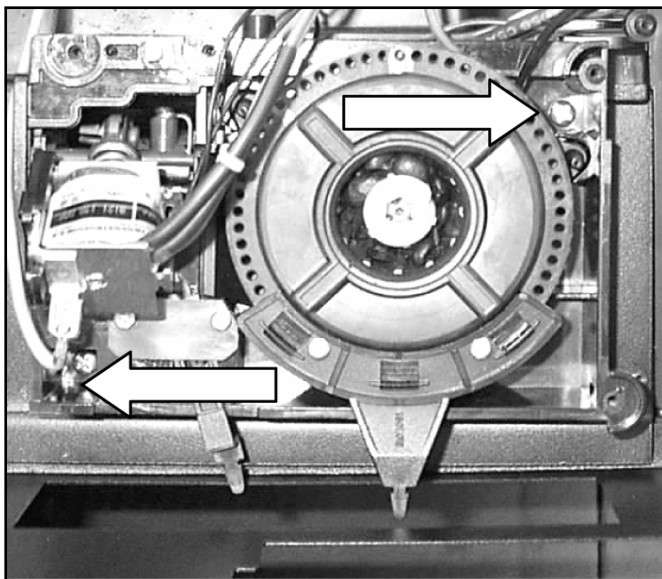

Figure 5-33: Grinder Retaining Screws

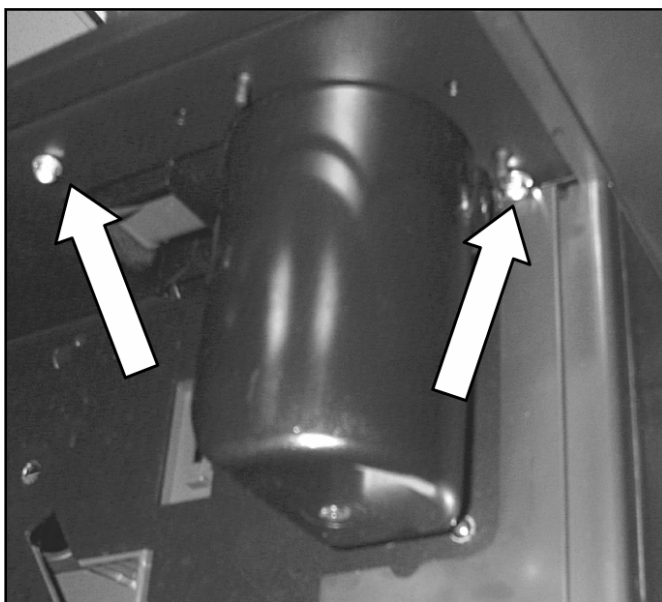
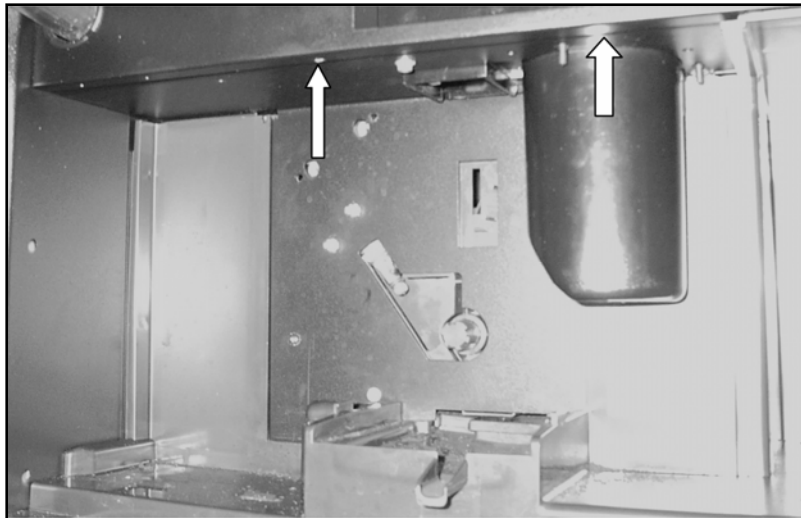

Figure 5-34: Grinder Retaining Nuts

**Technical Information**

20. Remove the knobs from the Grinder Slide Controls.
21. Remove the Adjustment Slide Switch Frame (5.4).
22. Position the Grinder as necessary to access the Drive Cover and Drive Unit Retaining Screws. Refer to Figure 5-34 for the location of the screws.
23. Remove the two Upper Front Plate Assembly Retaining Screws – as shown in Figure 5-35.
24. Remove all remaining screws from the Front Plate Assembly. Lift upward on the Front Plate Assembly to access the screws near the bottom of the plate. Use Figure 5-32 to locate all screws.



**Figure 5-35:** Upper Front Plate Assembly Retaining Screws

25. Move the Drive Assembly Cover toward the rear wall of the appliance.
26. Move the Drive Assembly back while lifting upward to remove it from the appliance. Use caution – a short length of wiring.



**Service Tip:**

Refer to Figure 5-36. To avoid having to hold the Front Plate Assembly upward while removing the lower screws, a suitable item can be used to temporarily keep the Front Plate Assembly in an elevated position.



**Figure 5-36:** Using a Suitable Item to Keep the Front Plate Assembly Elevated to Access the Screws at the Bottom

27. Position the Drive Assembly so access to the rear cover is possible.
28. Remove the 5 screws that secure the cover.
29. Lift the cover from the Drive Unit.
30. Refer to Section 4.15 – Brew Unit Drives for information on the Drive Assembly.

## Technical Information

**5.33 Water Tank Float - Removal**

1. Open the door.
2. Remove the Water Tank.
3. Remove the cap from the Water Tank.
4. Remove the Water Tank Float.

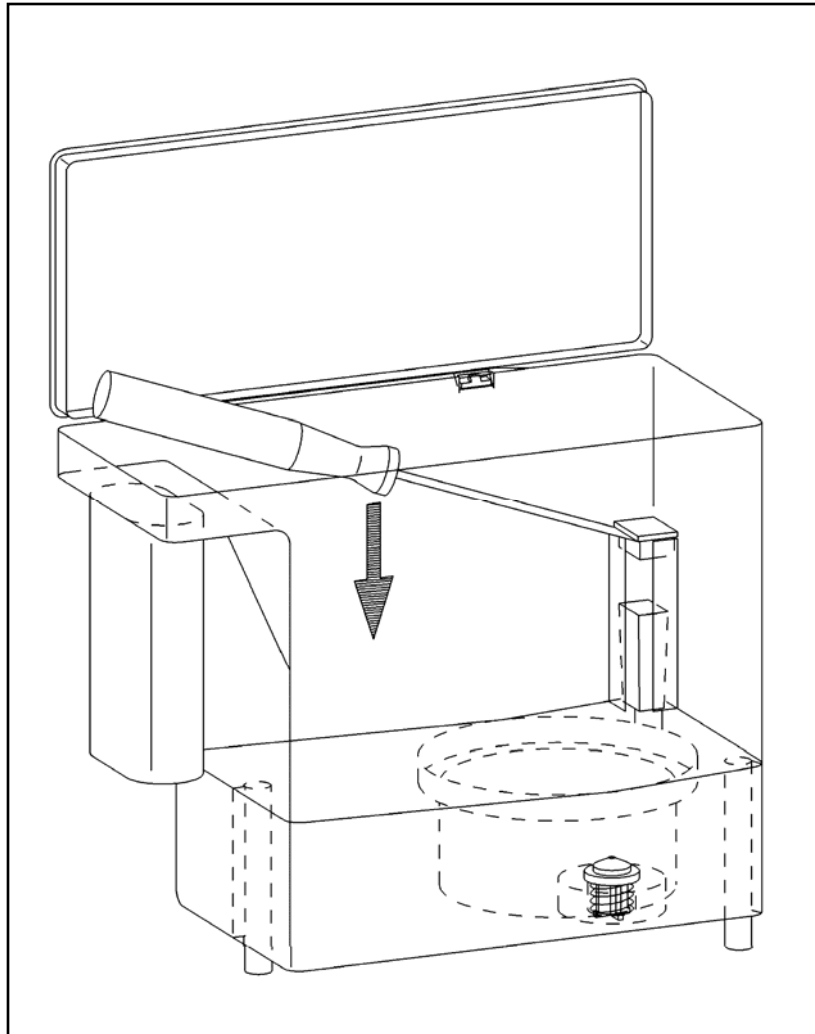

**Figure 5-37:** Removing the Cap to Access the Float in the Water Container

## 5.34 Water Tank Lip Seal - Removal

1. Open the door.
2. Remove the Water Tank – Refer to Section 5.33.

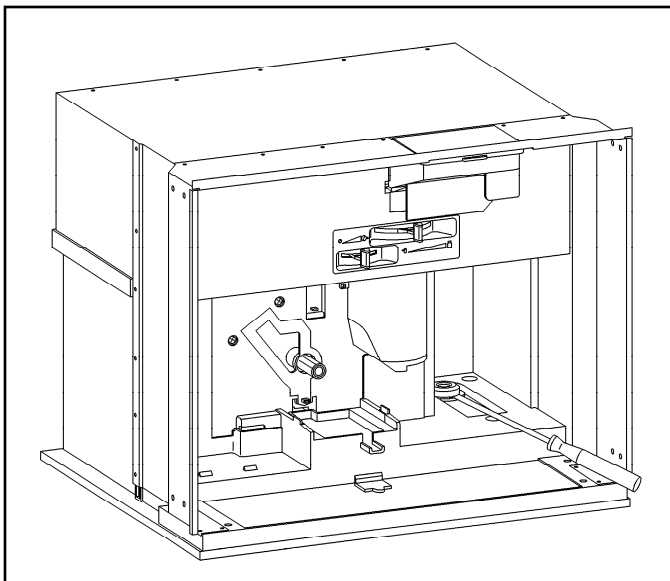

**Figure 5-38:** Levering Off the Lip Seal Cap

3. Lever off the Lip Seal Cap.
4. Remove the Lip Seal.

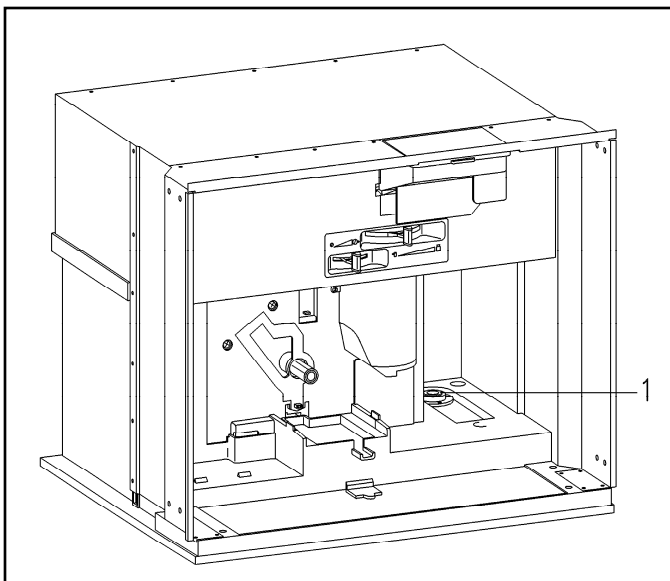
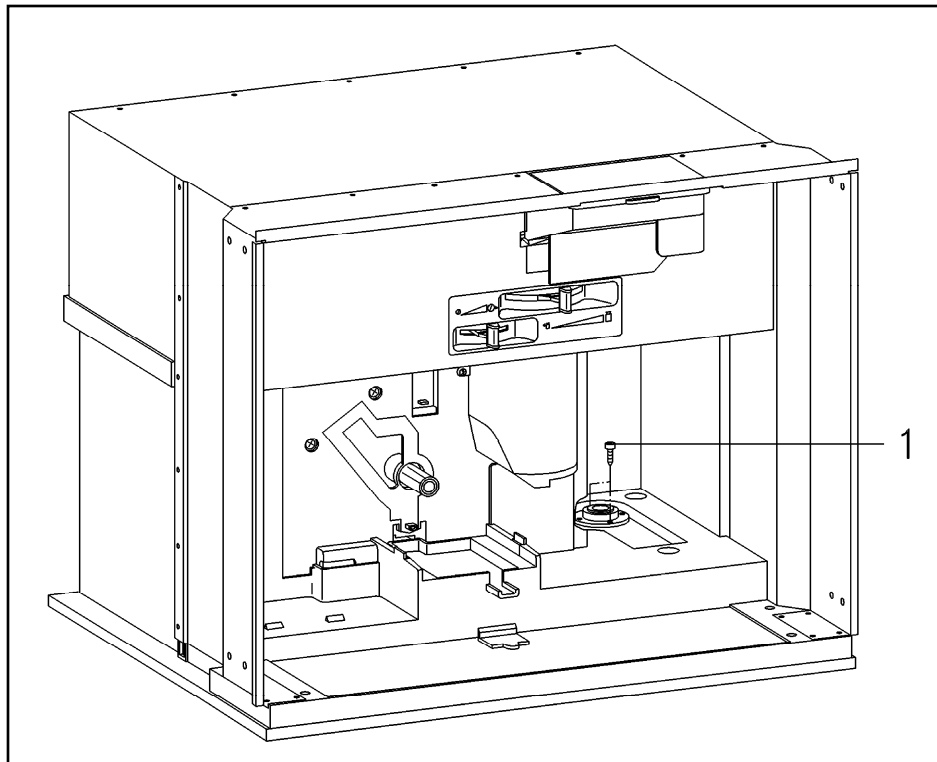

**Figure 5-39:** Removing the Lip Seal

## Technical Information

**5.35 Lower Section of Tank Valve - Removal**

1. Open the door.
2. Remove the Water Tank – Refer to Section 5.33.
3. Remove the Lip Seal (Refer to Figure 5-39).
4. Remove the lower part of the Valve Fixing Screws (Figure 5-40, Item 1).

**Figure 5-40: Water Tank Lip Seal Removal**

5. Remove the Bottom Plate and Drip Tray.
6. Disconnect the lower part of the valve connections.
7. Remove the lower part of the valve.

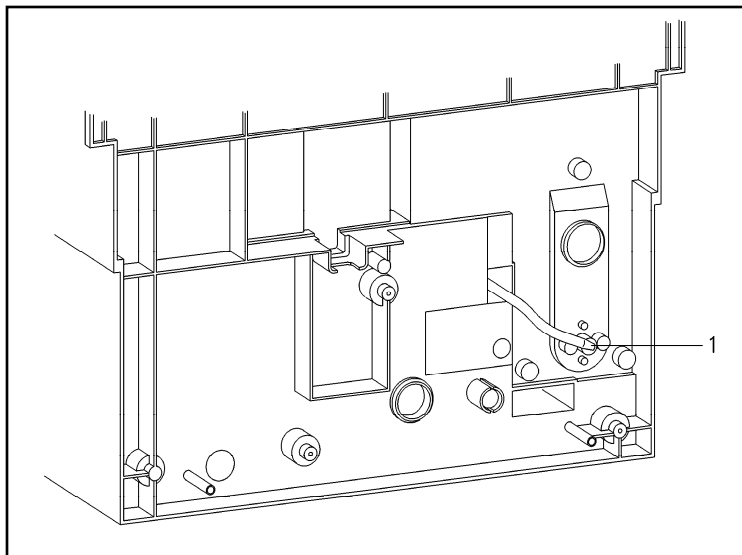
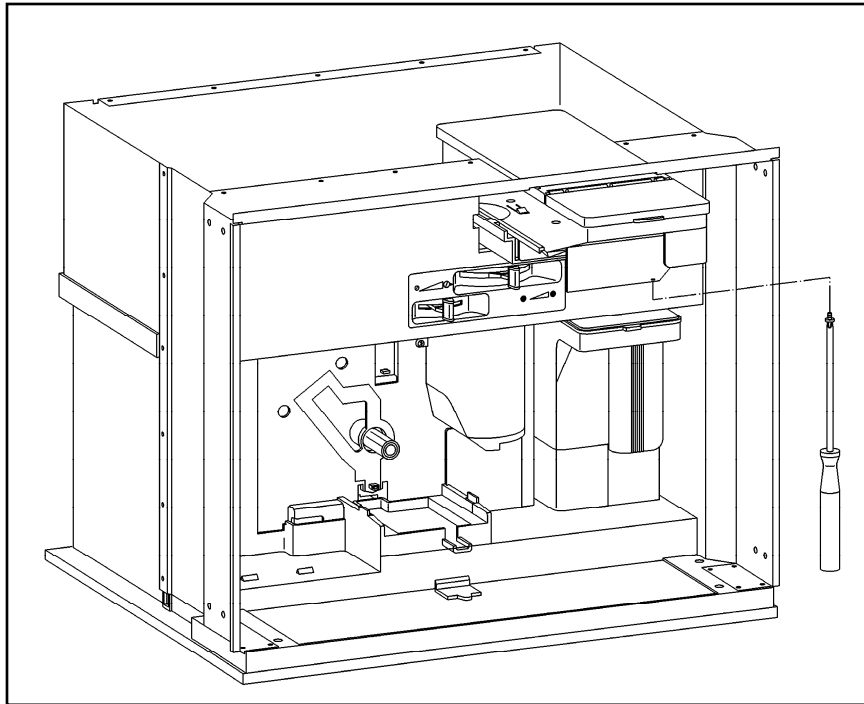

**Figure 5-41:** Underside View of the CVA615 with Base Plate and Drip Tray Removed

## Technical Information

**5.36 Beans Container - Removal**

1. Open the door.
2. Remove the Beans Container End Stop Screw (Figure 5-42).
3. Hold a suitable container under the beans container opening to collect loose beans, remove the beans container.

**Figure 5-42:** Removing the Beans Container

## 5.37 Beans Container Guide - Removal

1. Open the door.
2. Perform the "Beans Container Removal" procedure.
3. Remove the Waste Container, Brew Unit and Water Tank.
4. Remove the Top Lid.
5. Remove the guide retaining screws (Figure 5-43, Item 2).
6. Remove the guide and carrier (Figure 5-43, Item 1).

**Note:**

During installing, first fit the carrier (Figure 43, Item 1) in position and then fit the guide on the carrier.

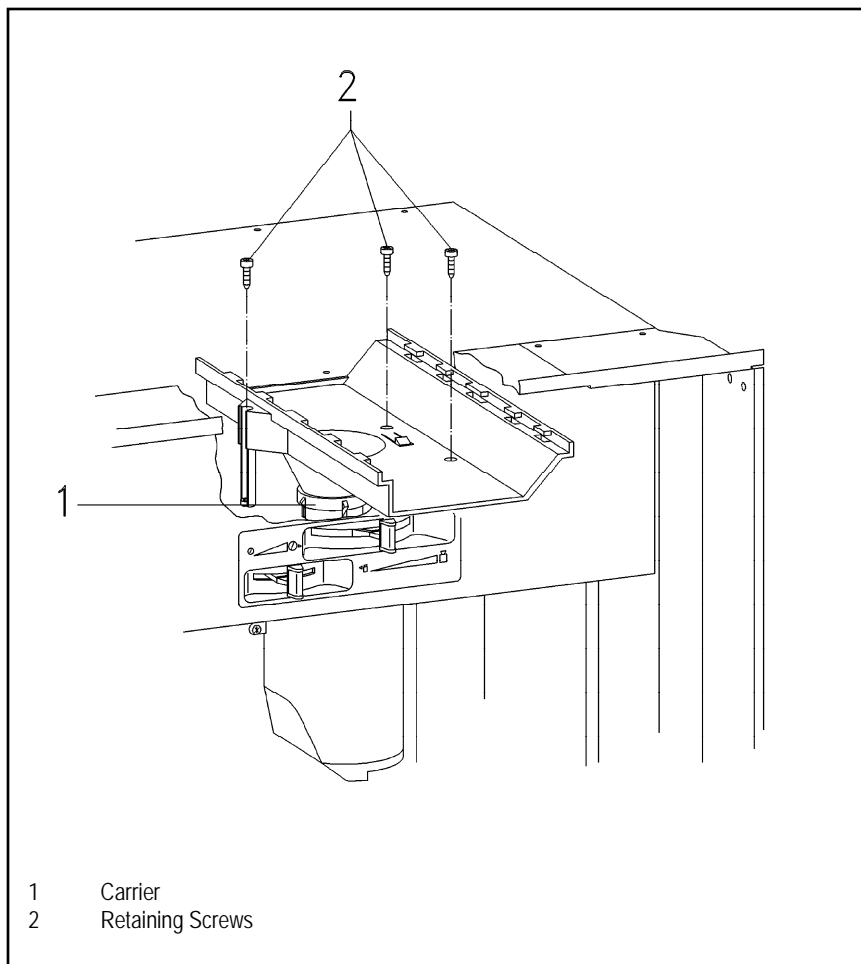

**Figure 5-43:** Beans Container Guide

## Technical Information

**5.38 Grinder - Disassembly****Note:**

The Grinder Ring and Grinder Cone should only be replaced as a set.

1. Open the door.
2. Remove the Beans Container – Refer to Section 5.36.
3. Remove the Waste Container, Brew Unit and Water Tank.
4. Remove the Top Lid.
5. Remove the Beans Container Guide – Refer to Section 5.37.
6. Set the grinding grade adjustment lever to the mid setting.

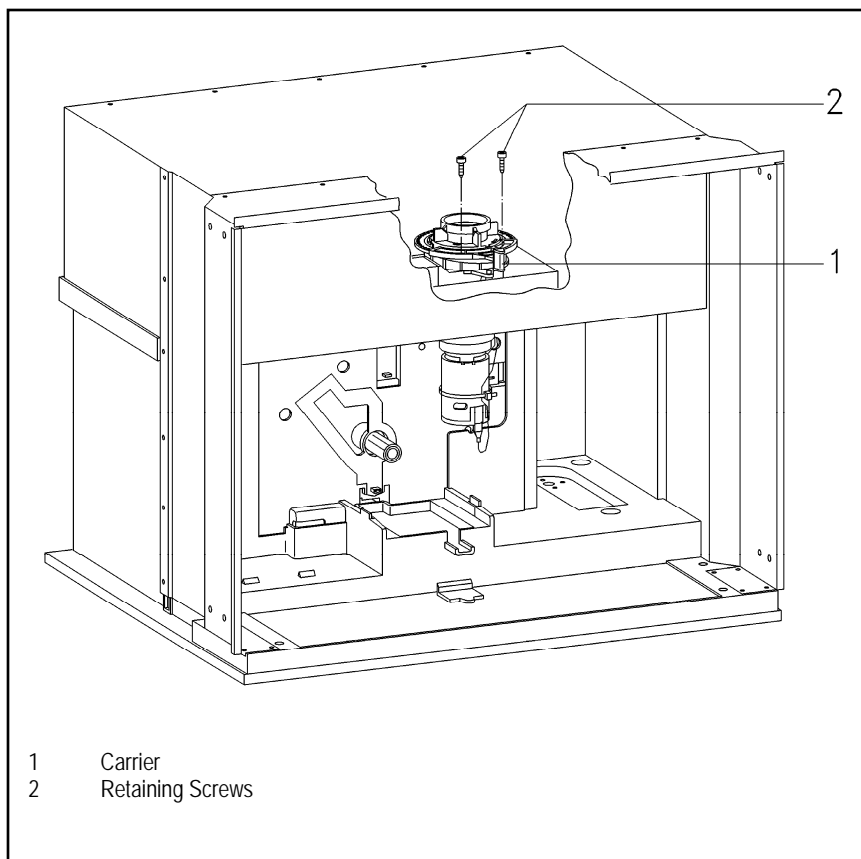
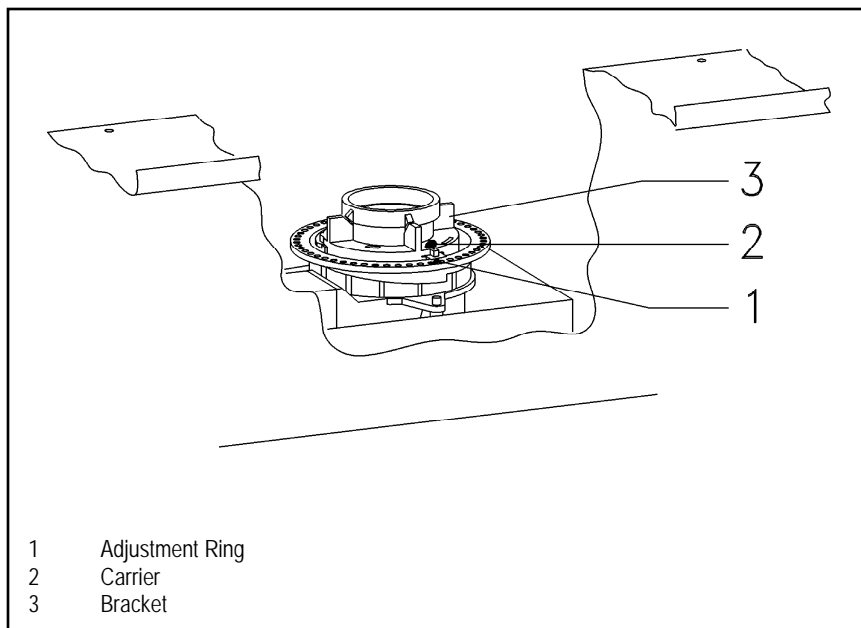

**Figure 5-44:** Grinder - Disassembly

7. Pull off the handle (Figure 5-44, Item 1).
8. Remove the Adjustment Lever Fixing Screws (Figure 44, Item 2) and the Adjustment Lever.



9. Turn the Adjustment Ring (Figure 5-45, Item 1) counterclockwise until the blue marking aligns with the blue marking on the carrier (Figure 5-45, Item 2).



**Figure 5-45:** Grinder

10. Remove the bracket (Figure 5-45, Item 3).
11. Remove the coffee residues, e.g. with a vacuum cleaner.

**Note:**

The Grinding Cone Fixing Screw has a left-hand thread.

12. Remove the grinding cone fixing screw (Figure 5-46, Item 1) by turning it clockwise.
13. Remove the intake worm gear (Figure 5-46, Item 2).
14. Remove the washer (Figure 5-46, Item 3).

**Note:**

When the Grinding Cone (Figure 5-46, Item 6) is removed, the balls (Figure 5-41, Item 8) may stick to it and then fall off.

**Technical Information**

Refer to Figure 5-46 – Grinder – Apart

15. Remove the Grinding Cone (Item 6).
16. Remove the balls (Item 8).
17. Remove the mounting (Item 7).
18. Remove the springs (Item 9).
19. Remove the carriers (Item 10).
20. Remove the felt ring (Item 11).

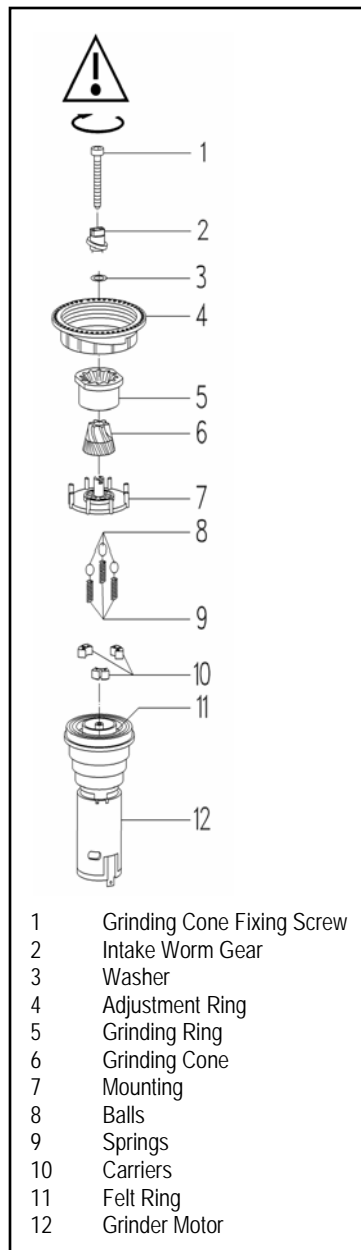

**Figure 5-46:** Grinder - Apart

## 5.39 Grinder Assembly – Basic Setting

Refer to Figure 5-46 – Grinder - Apart.

**Note:**

Before setting the grinder, remove all coffee from the grinder.

1. Install the Felt Ring (Item 11).
2. Install the carriers (Item 10).
3. Install the mounting (Item 7).
4. Install the springs (Item 9).
5. Install the balls (Item 8).
6. Install the Grinding Cone (Item 6), ensure the balls are seated.
7. Install the washer (Item 3).
8. Install the Intake Worm Gear (Item 2), press down, and turn until the coupling engages.
9. Tighten the Grinding Cone Screw (Item 1) counter clockwise. (Ensure the intake worm gear coupling has engaged properly).

**Note:**

Before setting the grinder, remove all coffee from the grinder.

10. Fit the bracket (Item 3).
11. The blue marking on the carrier (Item 2), has the same position as the blue marking on the adjustment ring (Item 1); both point toward the front of the appliance.
12. Turn the Adjustment Ring Clockwise as far as possible.
13. Turn the Adjustment Ring Counterclockwise by 6 settings so that the Adjustment Lever can be secured at a mid setting.
14. Fit the Adjustment Lever such that the grinder is set to a medium grinding grade.
15. Tighten the Adjustment Lever Fixing Screws.
16. Push on the handle.

## Technical Information

**5.40 Grinder Unit - Removal**

1. Open the door.
2. Remove the Beans Container – Refer to Section 5.36.
3. Remove the Waste Container, Brew Unit and Water Tank.
4. Remove the Top Lid.
5. Remove the Beans Container Guide – Refer to Section 5.37.
6. Remove the Adjustment Slide Switch Frame.
7. Remove the Adjustment Lever Fixing Screws and Lever.
8. Remove the cover fixing screws (Figure 5-47, Item 4).
9. Remove the cover.

**Note:**

Mark the polarity of the plug (Figure 5-48, Item 1) connected to the electronic unit.

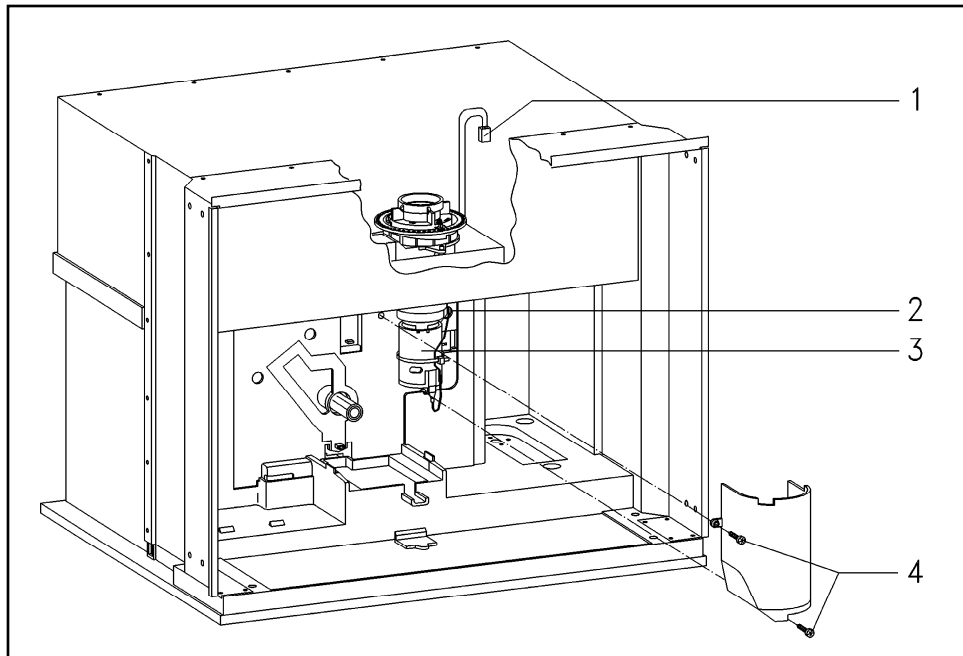
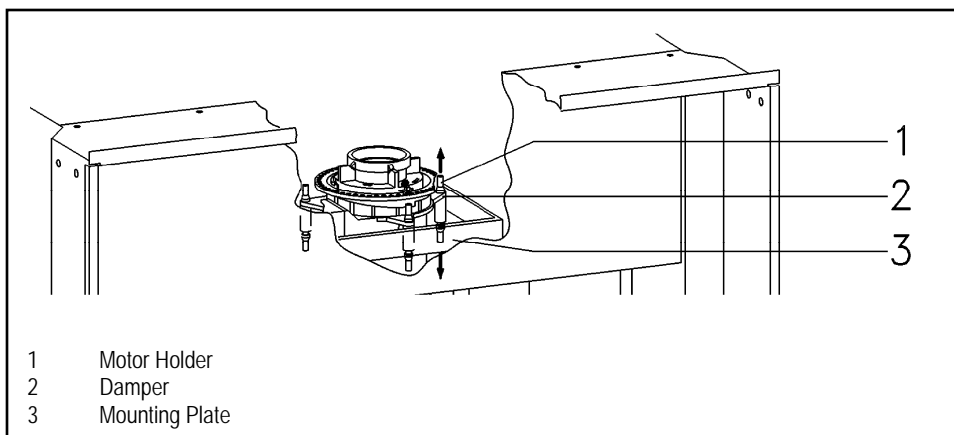

Figure 5-47: Grinder Removal

10. Remove the plug from the electronic unit.
11. Lift the grinder upwards from the dampers (Figure 5-48, Item 2).



**Figure 5-48:** Grinder Coupling

**Note:**

When installing the grinder, the dampers should be firmly seated in the mounting plate and motor holder. Ensure the grinder coupling is completely secured so grinder noise is kept to a minimum.

## 5.41 Dispensing Solenoid - Removal

1. Remove the Top Lid.
2. Remove the Rear Panel – Refer to Section 5.10.
3. Remove the Beans Container – Refer to Section 5.36.
4. Remove the Beans Container Guide – Refer to Section 5.37.
5. Press the retainers outward.
6. Slide the Dispensing Solenoid upward out of the guide.
7. Disconnect the electrical connections.

## 5.42 Dispenser Switch - Removal

1. Remove the Top Lid.
2. Remove the Rear Panel – Refer to Section 5.10.
3. Remove the Beans Container – Refer to Section 5.36.
4. Remove the Beans Container Guide – Refer to Section 5.37.
5. Remove the Dispensing Solenoid.
6. Press the retainers outwards. Remove the switch.
7. Disconnect the electrical connections.

## Technical Information

**5.43 Waterpath & Flowmeter - Testing****Caution!**

Hot water will flow from the water spout during this procedure.

1. Fill the water reservoir.
2. Place the appliance into the Service Mode with the Selector Knob in the Programming position. Refer to Section 6 – Fault Diagnosis for further information on service mode access.
3. Press and hold all three coffee buttons; the display shows the following:

<b>5678</b>	<b>34</b>
-------------	-----------

Does a pulsing (flickering) “8” appear in the top line of the display?

**NO**



Does water flow from the Hot Water Spout?

**NO**

The water is not flowing through the water path - check pump operation and water path for obstructions.

Correct fault & repeat test starting at step 1.

**YES**

Normal Operation – Proceed to Step 6

**YES**

a. Unplug JP25 from the CPU Electronic

b. Place a jumper between pins 2 & 3 (Figure 5-49).

c. Place the appliance into the Service Mode with the Selector Knob in the Programming position.



Does the display show a solid “8” in the top line of the display?

**NO**



Replace the electronic

**YES**



Replace the flowmeter

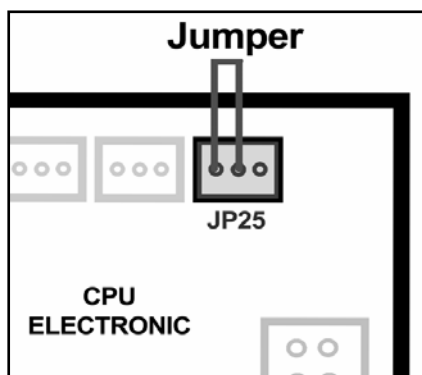

Figure 5-49: Test Jumper Position

4. Release all three coffee buttons.
5. Remove the jumper and reconnect JP25.
6. Press and hold all three coffee buttons. Observe the number displayed in the bottom right of display (refer to Figure 5-50).

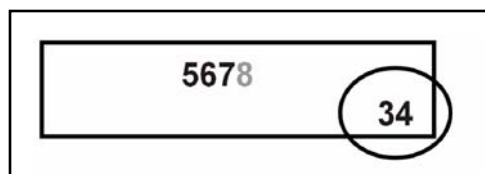

Figure 5-50: Display While in Service Mode

Is the displayed value 30 or higher?

**NO**



**Ensure...**

- Sufficient water is present
- The water path is clear
- Water lines are not crimped
- Heaters, flowmeter, etc. freely pass water
- Water valves fully open
- Water line connections are tight & do not leak

**YES**

Normal operation

## Technical Information

**5.44 Water Path Leakage Test**

In the event water is present in bottom of the appliance, or a leak is suspected; the following procedure will help in locating the source of the leak.

**Caution!**

Heaters can be hot during this test and hot water may escape from the system.

1. Fill the Water reservoir completely
2. Place the appliance into the Service Mode with the Selector Knob in the Programming position. Refer to Section 6 - Fault Diagnosis for further information on service mode access.
3. Press and hold all three coffee buttons - check for signs of leakage (dripping, squirting etc...)
4. Release the three coffee buttons to end the test

If steps 1-4 do not disclose any leaks - continue as follows.

5. Fill the Water reservoir completely
6. Place the appliance into the Service Mode
7. Quickly turn the selector knob to the "Operation" position
8. Press and hold all three coffee buttons for 30 seconds
9. Quickly turn the selector knob to the "Programming" position
10. Press and hold all three coffee buttons - check for signs of leakage (dripping, squirting etc...)
11. Release the three coffee buttons to end the test



## 5.45 Water Path Connections - Opening

**Danger!**

Risk of burning or scalding!

Components may be hot.

Pressurized steam may exist in the system.

Before any service work is performed, allow time to cool.

Refer to Figure 5-51 – Water Path Connection.

1. Remove the retaining spring (Item 1).
2. Pull out the hose from the connector.
3. Remove the sealing rings (Item 2).

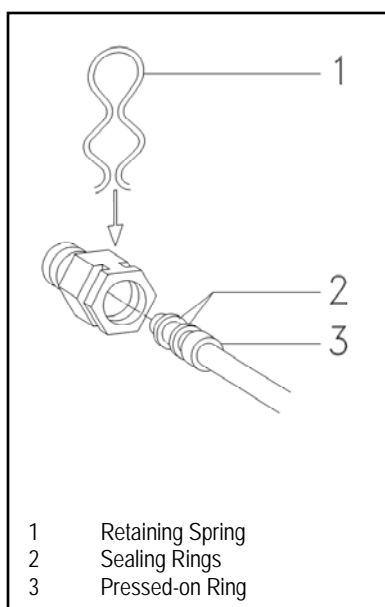

**Figure 5-51:** Water Path Connection

## 5.46 Water Path Connections - Closing

1. Check the sealing rings for damage and replace as necessary.
2. Fit the sealing rings on the hose.
3. Insert the hose in the connector.
4. Fit the retaining spring behind the pressed-on ring.
5. As a check, pull on the hose. It should not be possible to pull the hose out of the connector.

## Technical Information

## 6.0 Fault Diagnosis

### 6.1 Programming Mode

The Programming Mode is designed for access by the customer to for changes various setting and change features. To access the Programming Mode, simply turn the selector knob to the “Program Mode” position

The Programming Mode Consist of:

<b>Language</b>	German, Dutch, Portuguese, Spanish, English, Italian or French
<b>Rinsing</b>	On, Off
<b>Water Hardness</b>	Hardness Levels 1 to 4
<b>Temperature Long Coffee</b>	Minimum, Low, Medium, High, Maximum
<b>Temperature Coffee</b>	Minimum, Low, Medium, High, Maximum
<b>Temperature Short (Espresso) Coffee</b>	Minimum, Low, Medium, High, Maximum
<b>Pre-Brewing</b>	On, Off
<b>Pre-Grinding</b>	Off, On
<b>Program Hot Water</b>	Off, On
<b>Total Coffee</b>	Number of Coffee Servings
<b>Descaling</b>	Automatic Descaling Program
<b>Standby Timer</b>	Selectable in 15 Minute Periods

Table 6-1: Programming Mode Navigation

## 6.2 Service Mode

The Service Mode is used to check the status of various input switches and operate components in the appliance. The Service Mode is designed for accessed by qualified service personnel.

### Initial requirements

- Switch off the appliance
- Ensure the front door is closed

### Access

1. Press and hold the **SMALL COFFEE** button and the **HOT WATER** button.
2. Refer to the Service Mode chart on the following page... turn the selector knob to the desired position.
3. Release the **SMALL COFFEE** and **HOT WATER** buttons.
4. Press the applicable button to activate the function listed.

### Acknowledgement Indicator

The following is an example indicates the appliance is in the Service Mode:

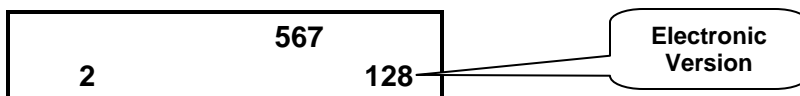

The display indicates the switches currently actuated.

1. Brewing position switch (brew unit drives)
2. Home position switch (brew unit drives)
3. Dispenser switch
4. Steam valve switch
5. Waste container present switch
6. Brew unit present switch
7. Water tank level switch
8. Flow meter pulse (not always displayed)
- A. Drip tray filled (water system fault)

**Technical Information**

<b>Service Mode - Navigation</b>		
LOCK	Large Coffee	Displays Water Temperature for Water Heater and Steam Heater in Celsius.
	Med Coffee	Displays firmware version
	Small Coffee	(not used)
	Hot Water	(not used)
	Rinse	(not used)
PROGRAM MODE	Large Coffee	Water Pump ON
	Med Coffee	Steam Solenoid ON
	Small Coffee	Hot Water Valve ON
	Hot Water	Displays 5
	Rinse	Displays 4
LIGHT	Large Coffee	Button Test "1" displayed
	Med Coffee	Button Test "2" displayed
	Small Coffee	Button Test "3" displayed
	Hot Water	Button Test "5" displayed
	Rinse	Button Test "4" displayed
ON W/ LIGHT	Large Coffee	Drive motor ON till Brew Position Switch is contacted
	Med Coffee	Drive motor ON (reverse direction) till Home Switch is contacted
	Small Coffee	Grinder ON
	Hot Water	(not used)
	Rinse	Dispenser Solenoid ON
ON	Large Coffee	Hot Water / Coffee Side Heater Element ON
	Med Coffee	Hot Water / Coffee Upper Heater Element ON
	Small Coffee	Steam Heater Element ON
	Hot Water	Front Lights (CVA615)
	Rinse	(not used)

**Table 6-2:** Service Mode Navigation

### 6.3 Displayed Messages

Displayed Message	Information
BREW UNIT BLOCKED	<p>The brew unit is dirty. The brew unit is blocked. The brew unit is Jammed.</p> <ul style="list-style-type: none"> <li>• Clean / inspect brew unit / check drives.</li> </ul>
EXPEL AIR	<p>Air is present with the water system –</p> <ul style="list-style-type: none"> <li>• Perform “Expel Air” procedure.</li> </ul>
FILL COFFEE BEANS	<p>The bean container is empty OR The grinder may be jammed.</p> <ul style="list-style-type: none"> <li>• Add coffee beans to the beans container.</li> <li>• Clean the conical grinder (top of grinder).</li> </ul>
BREW UNIT MISSING	<p>Brew unit is not installed OR Not installed correctly.</p> <ul style="list-style-type: none"> <li>• Reinstall the brew unit.</li> <li>• Check brew unit present switch.</li> </ul>
DESCALING	<p>Perform the Descale Procedure.</p>
WASTE UNIT MISSING	<p>Waste unit is not installed.</p> <ul style="list-style-type: none"> <li>• Re-install the waste unit.</li> <li>• Check magnet on rear of waste unit.</li> <li>• Check brew unit present switch.</li> </ul>
STANDBY...	<p>The appliance is in the energy saving mode</p> <ul style="list-style-type: none"> <li>• Press ENTER</li> </ul>

**Table 6-3:** Displayed Messages (Continued on Table 6-4)

## Technical Information

Displayed Message	Information
WATER SYSTEM FAULT	<p>The level switch has been actuated by water being present in the base of the appliance.</p> <ul style="list-style-type: none"><li>• Clear unit of water from lower pan and locate / repair source of leak.</li><li>• Check level switch for proper operation.</li></ul>
FILL WATER TANK	<p>The water tank level switch is not actuated – water tank float is below the switch level.</p> <ul style="list-style-type: none"><li>• Refill the water tank.</li><li>• Check that float and switch operate.</li></ul>
EMPTY WATER TANK	<ul style="list-style-type: none"><li>• Check that flowmeter is plugged into the correct position of the electronic.</li></ul>
WARMING UP...	<p>Appliance is warming up, as warming up the “...” in the display disappear.</p>

**Table 6-4:** Displayed Messages (Continued from Table 6-3)

## 6.4 Fault Diagnosis

**When two cups of coffee / espresso are being prepared at the same time, the cups are filled unevenly.**

- Appliance is not level.
  - Level the appliance
- Coffee nozzle is dirty.
  - Clean the coffee nozzle.

**Brew Unit cannot be removed from the appliance.**

- The brew unit is not in the starting (home) position.
  - Reset the brew unit to the starting (home) position.
- The brew unit is jammed and cannot be removed by resetting the appliance (i.e. shutting the door and turn on the power).
  - Perform the manual removal procedure.
  - Inspect the brew unit and/or drives to locate fault.

**Brew Unit cannot be installed**

- The part marked PRESS was pressed during installation of the Brew Unit.
  - Do not press the part marked PRESS when installing the Brew Unit; this only applies during Brew Unit removal.
- The Brew Unit is not in the starting (home position).
  - Perform a manual resetting of the Brew Unit.
- The drive shaft is not in the starting (home) position.
  - Reset the Brew Unit to the starting (home) position via the Service Mode.
  - Carefully inspect the Brew Unit and/or drives to locate fault (i.e. defective switch etc...)

**Technical Information****Grinding grade cannot be set finer (adjustment lever appears jammed)**

- Ground coffee is between the grinding ring and grinding cone.
- The ground coffee prevents the gap between the grinding ring and grinding cone from being reduced.
  - Perform the following:
    1. Set the adjustment lever to the finest setting possible.
    2. Prepare a coffee.
    3. Set the adjustment lever to a finer setting.

**Warning!**

To avoid damage to the grinder, the grinding grade should only be adjusted in small steps.

INITIAL: 3/23/2007 L.G.

---